

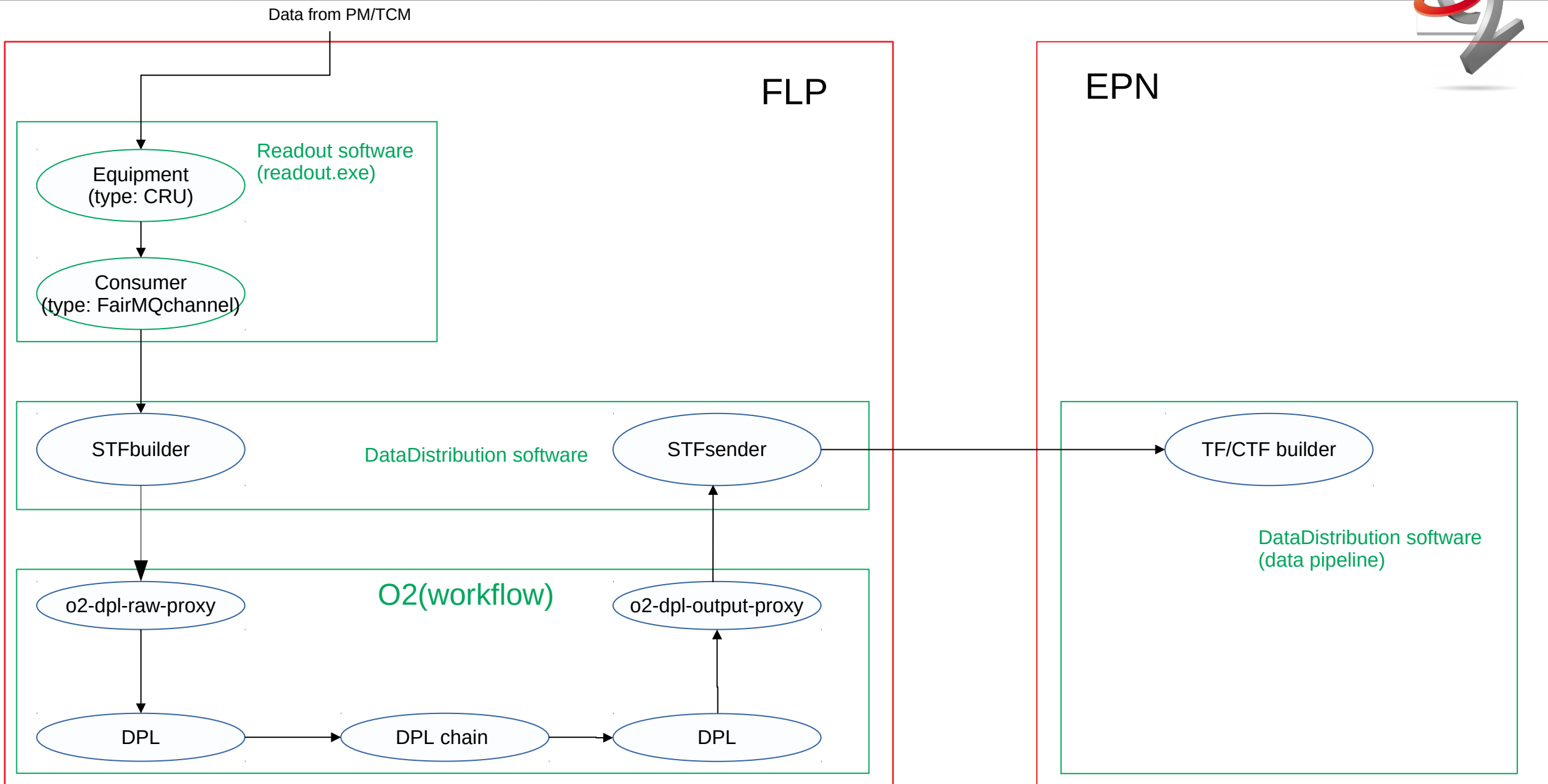

FLP FIT status

Artur Furs, INR, FIT meeting

FLP FT0 schematics



Readout schematics



Hardware(physical) level

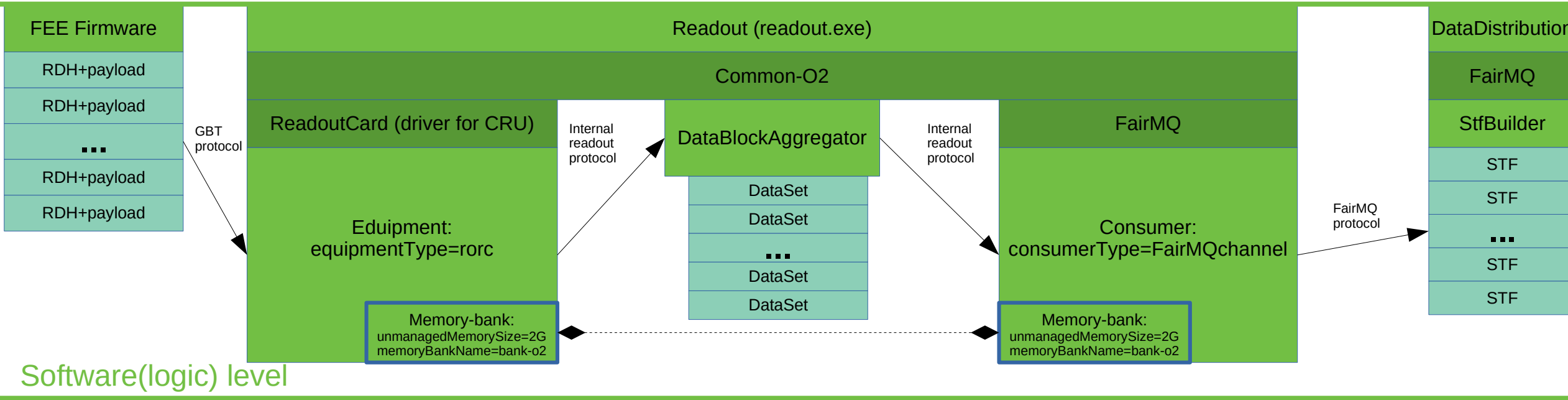
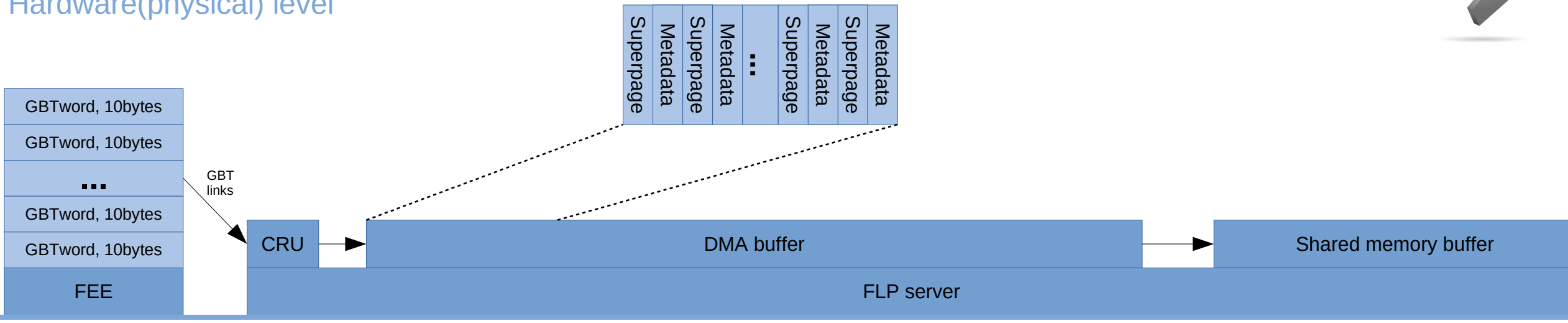

Software(logic) level

Readout data structure schematics



Hardware(physical) level

memoryBankSize=memoryPoolPageSize(2MB)*(memoryPoolNumberOfPages+1)

Software(logic) level

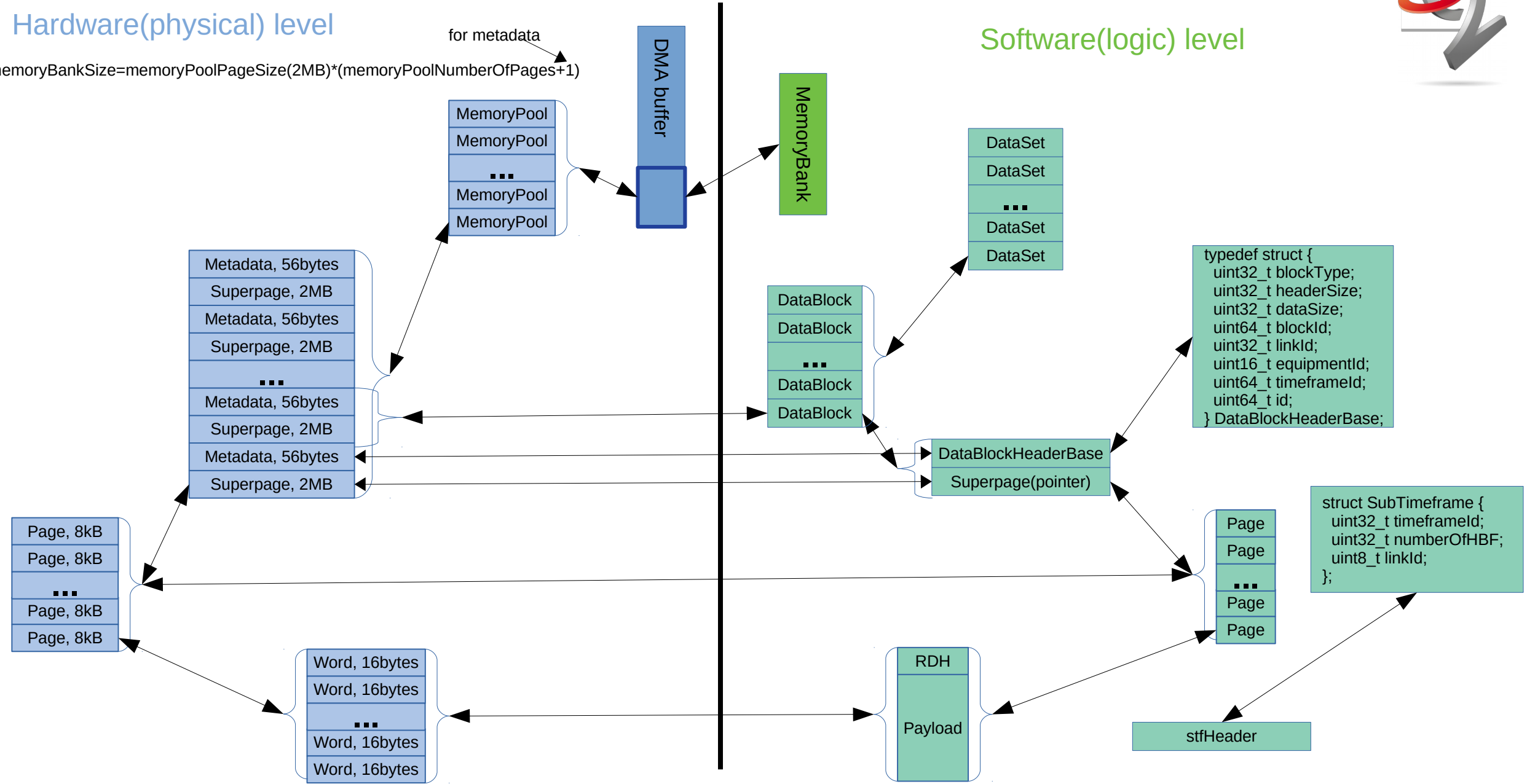

Readout(Equipment CRU) data flow schematics



Hardware(physical) level

Software(logic) level

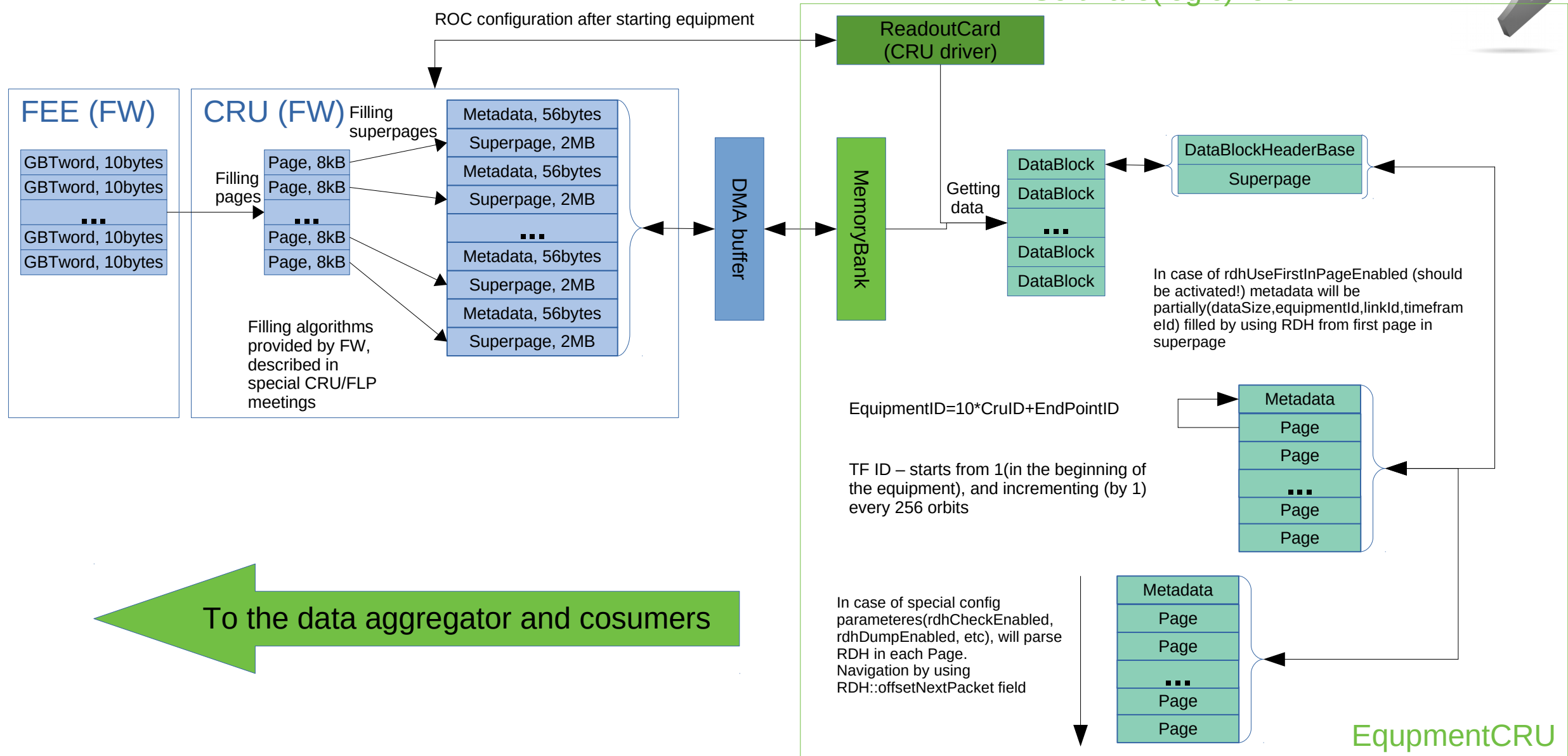

Readout(DataAggregator and ConsumerFairMQ) data flow schematics



DataAggregator

Packing DataBlocks into DataSets
Three options available:

- Default: one DataBlock into one DataSet
- Slicing: DataBlock with same (EquipmentID, linkID, TF ID) tuple into one DataSet. DataSets ordered by (EquipmentID, linkID) tuple, from left to right component of the tuple (ordering by EquipmentID, if its same then ordering by linkID).
- Slicing + PreSTFbulding: After slicing, DataSets will be additionally ordered by TF ID in case of the same (EquipmentID, linkID) tuple.

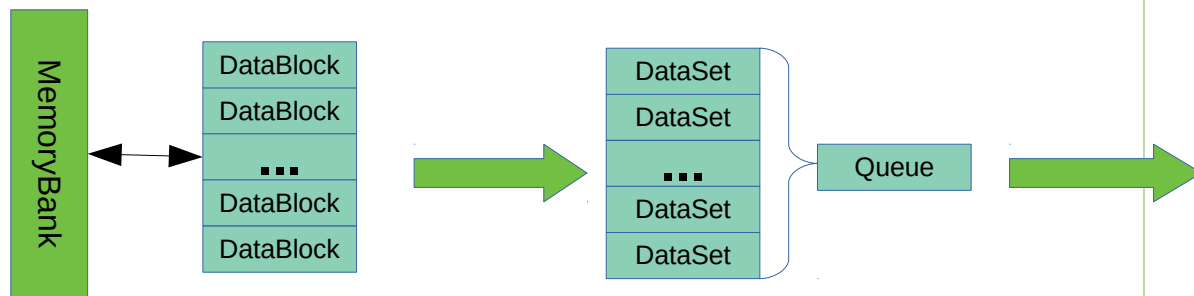

Slicing example:

DataSet: EqID2 LinkID2 TF?	DataSet: EqID2 LinkID2 TF?	DataSet: EqID2 LinkID1 TF?	DataSet: EqID2 LinkID1 TF?	DataSet: EqID1 LinkID2 TF?	DataSet: EqID1 LinkID2 TF?	DataSet: EqID1 LinkID1 TF?	DataSet: EqID1 LinkID1 TF?
-------------------------------------	-------------------------------------	-------------------------------------	-------------------------------------	-------------------------------------	-------------------------------------	-------------------------------------	-------------------------------------

Queue

Slicing+PreSTFbulding example:

DataSet: EqID2 LinkID2 TF2	DataSet: EqID2 LinkID2 TF1	DataSet: EqID2 LinkID1 TF2	DataSet: EqID2 LinkID1 TF1	DataSet: EqID1 LinkID2 TF2	DataSet: EqID1 LinkID2 TF1	DataSet: EqID1 LinkID1 TF2	DataSet: EqID1 LinkID1 TF1
-------------------------------------	-------------------------------------	-------------------------------------	-------------------------------------	-------------------------------------	-------------------------------------	-------------------------------------	-------------------------------------

Software(logic) level

ConsumerFMQchannel:

- one superpage -> one FairMQmessage (Backup Slides)
- DataSet(set of superpages) + stfHeader -> one FairMQparts (Backup slides)
- WP5 format: 1 FMQ message for header + 1 FMQ message per HBF , all belonging to same CRU/link id

Readout(ConsumerFairMQ) data flow schematics



Software(logic) level

Consumer FairMQchannel

(WP5 format: 1 FMQ message for header + 1 FMQ message per HBF (all belonging to same CRU/link id))

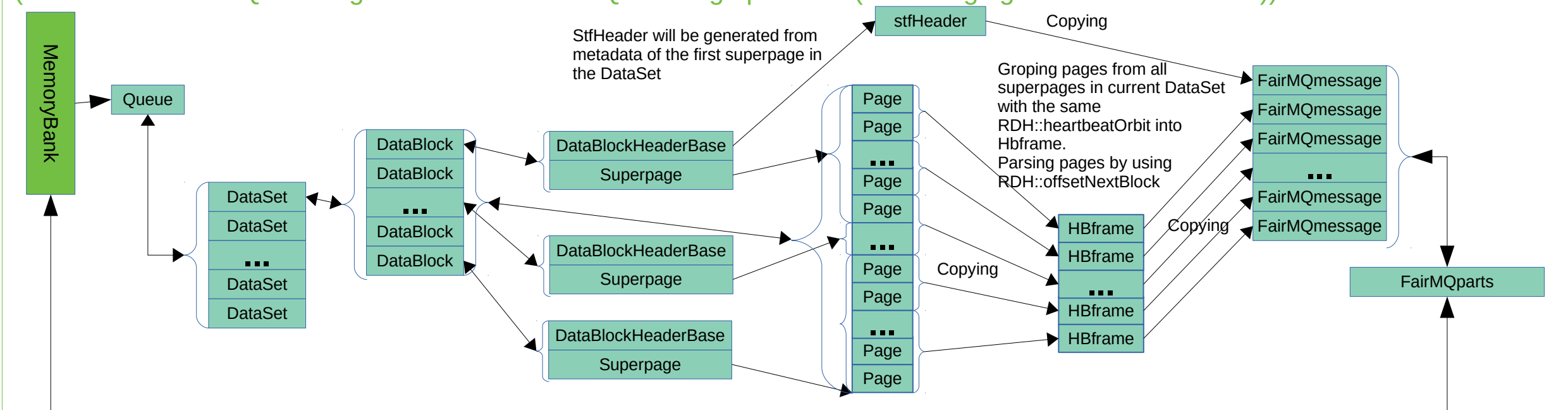

Hardware(physical) level

DMA buffer



Shared memory

Readout HOWTO



README for config file:

<https://github.com/AliceO2Group/Readout/blob/master/doc/configurationParameters.md>

ConfigParam	Component	Monitoring?	important?	Comments
rdhCheckEnabled	EquipmentCRU	+	+	
rdhDumpEnabled	EquipmentCRU	+	-	
rdhDumpErrorEnabled	EquipmentCRU	+	-	
rdhUseFirstInPageEnabled	EquipmentCRU	-	-	Should be true for filling metadata in each DataBlock
cleanPageBeforeUse	EquipmentCRU	-	-+	Optional, after payload page will be filled by zeros instead of garbage in the memory
aggregatorStfTimeout	DataAggregator	-	-+	For slicing should have value upper than zero (>0)
disableAggregatorSlicing	DataAggregator	-	-+	
aggregatorSliceTimeout	DataAggregator	-	-+	>0
memoryPoolPageSize	Equipment/Consumer	-	+	Size of superpage (2MB)
memoryPoolNumberOfPages	Equipment/Consumer	-	+	Number of superpages in memory pool, usually 1000-2000
memoryBankName	Equipment/Consumer	-	+	Use "o2-bank" for data flow (this bank internally defined in Readout software in case of common dataflow at FLP, no need to define this memory bank in config file)

Start Readout:

readout.exe file:your_config_file

DataDistribution(StfBulder) data flow schematics



DataDistribution

Software(logic) level

StfBulder

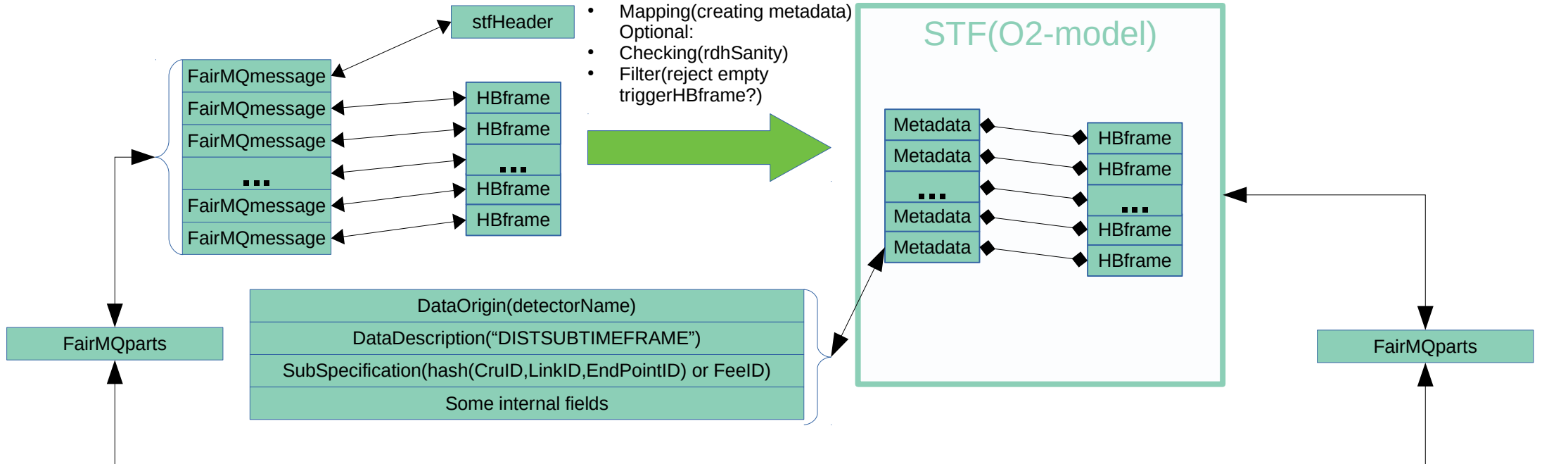

- Mapping(creating metadata)
- Optional:
 - Checking(rdhSanity)
 - Filter(reject empty triggerHBframe?)

Shared memory

Shared memory

Hardware(physical) level



DataDistribution(StfBuilder) HOWTO

DataDistribution README: <https://github.com/AliceO2Group/DataDistribution>

ConfigParameters	Important	Comments
rdh-data-check	-+	RDH sanity check
rdh-filter-empty-trigger	-+	Empty triggerHBframes rejection
detector-subspec	-+	Choose hash function for SubSpecification
detector	+	DataOrigin

Start DataDistribution:

```
StfBuilder --id stf_builder-0 --transport shmем --detector FT0 --session "default" --dpl-channel-name=dpl-chan --channel-  
config "name=dpl-chan,type=push,method=bind,address=ipc:///tmp/stf-builder-dpl-pipe-  
0,transport=shmем,rateLogging=1" --channel-config  
"name=readout,type=pull,method=connect,address=ipc:///tmp/readout-pipe-0,transport=shmем,rateLogging=1
```

DataDistribution+DPL schematics



Hardware(physical) level

Shared memory buffer

FLP server

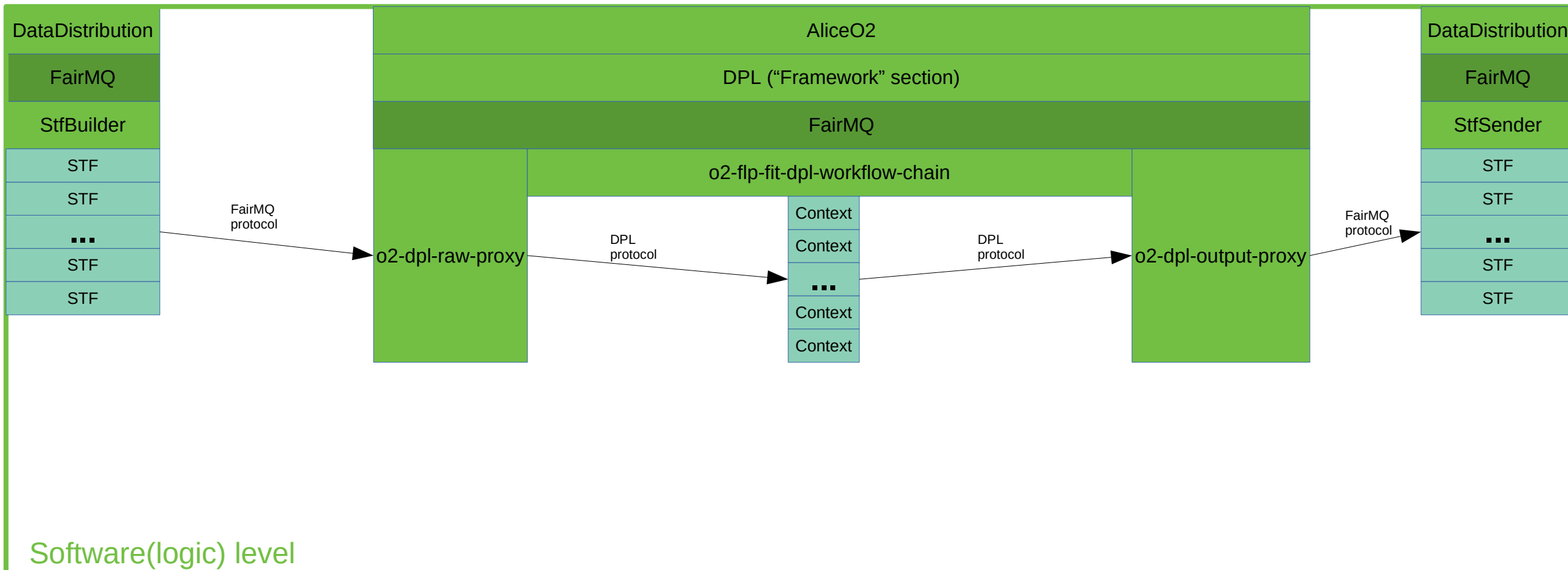

DPL(Proxy) data flow schematics



o2-dpl-raw-proxy

Software(logic) level

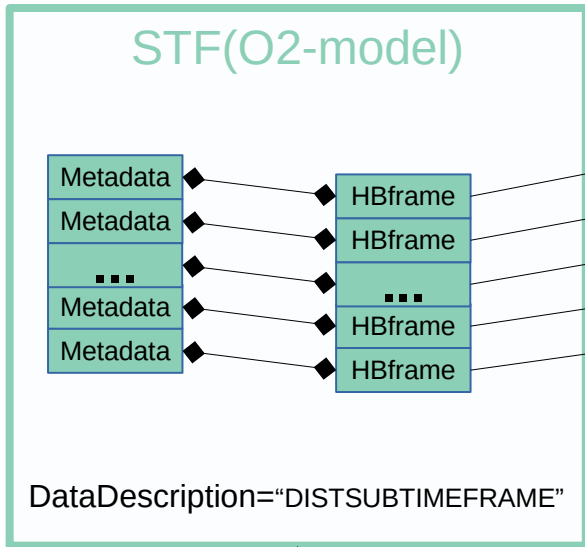

Pushing Hbframes into corresponding inputSpec

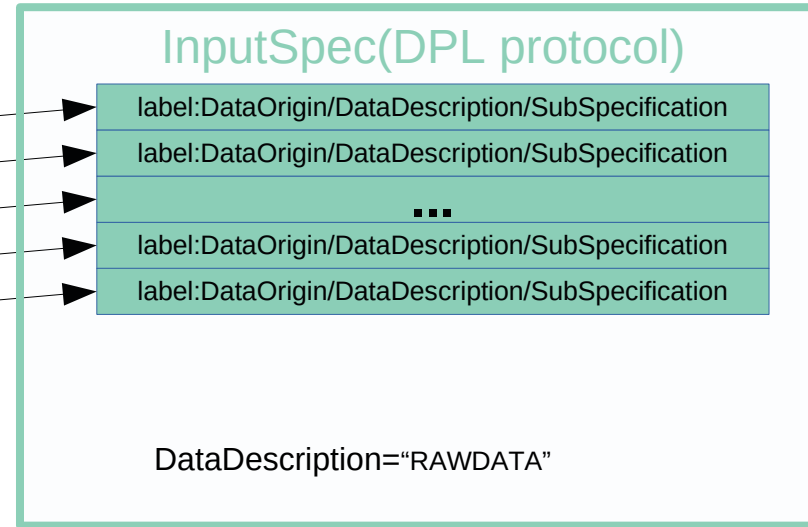
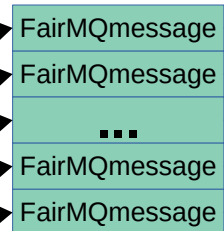

FairMQparts

FairMQparts

Shared memory

Shared memory

Hardware(physical) level

DPL(User-defined) data flow schematics



DPL chain

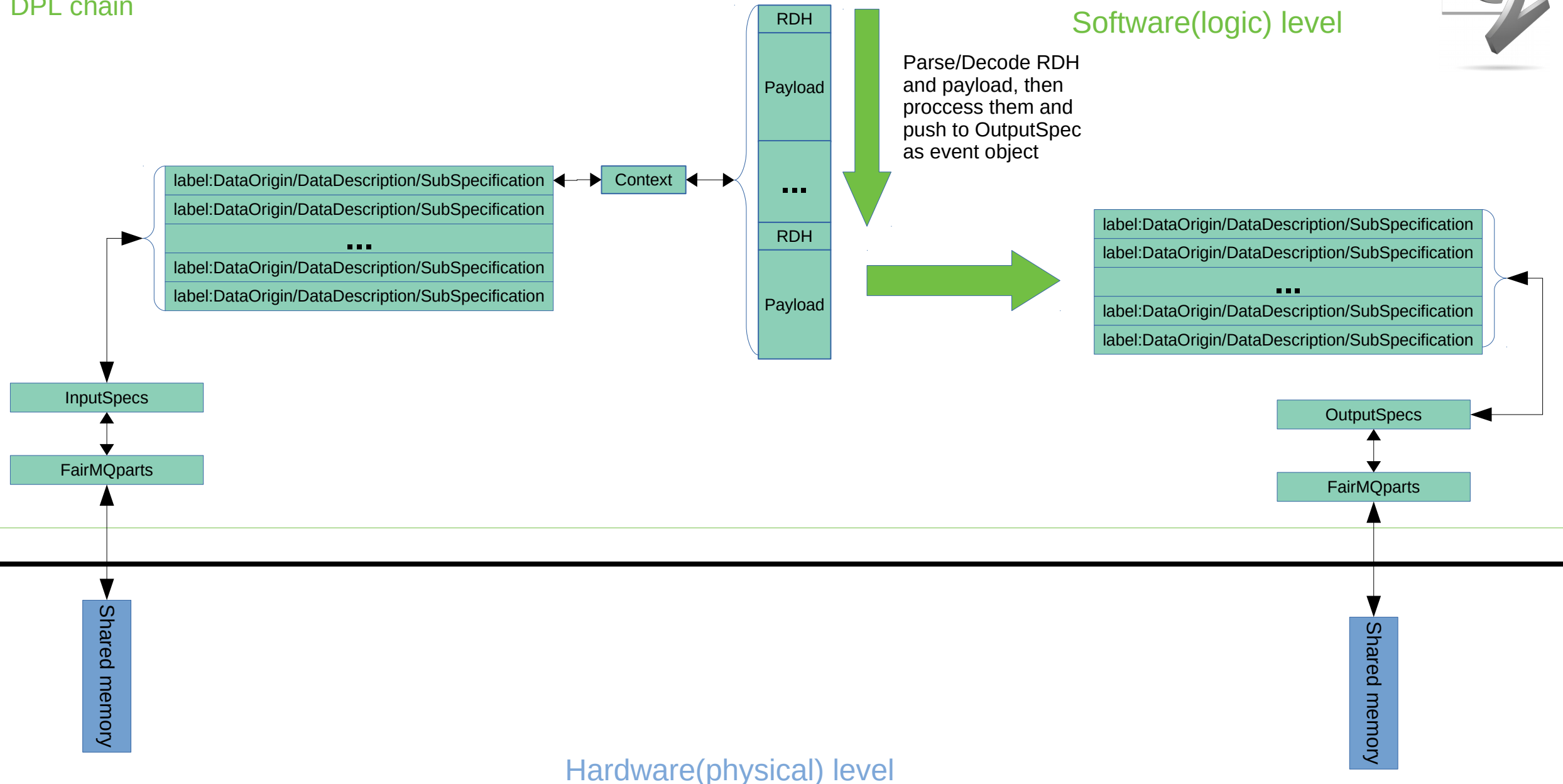

Hardware(physical) level

DPL(User-defined) data flow schematics

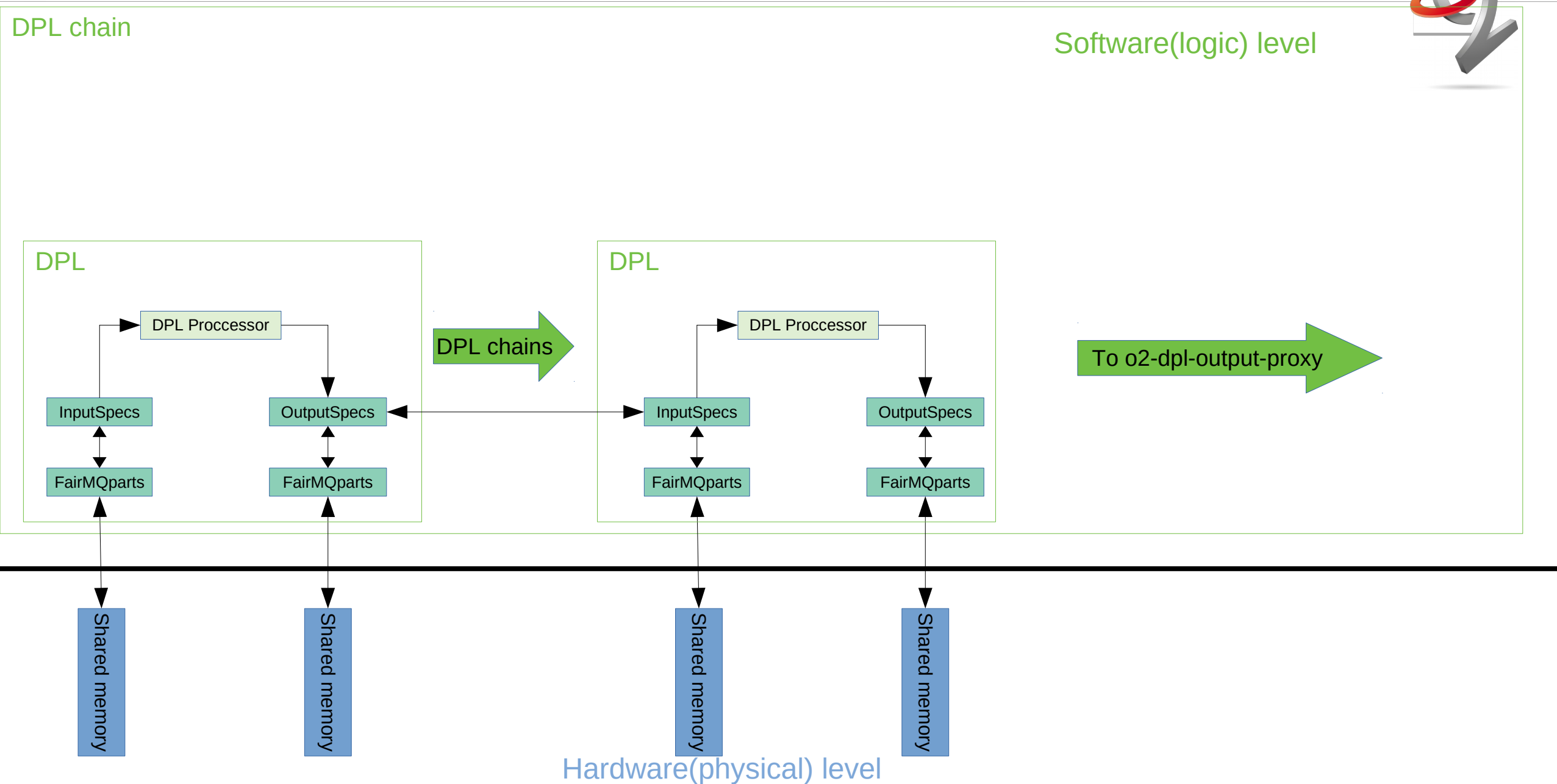

O2 DPL HOWTO



- README: <https://github.com/AliceO2Group/AliceO2/tree/dev/Framework/Utils>

- Start o2-dpl-raw-proxy:

```
o2-dpl-raw-proxy -b --dataspec "A:FT0/RAWDATA" --channel-config "name=readout-proxy,type=pull,method=connect,address=ipc:///tmp/stf-builder-dpl-pipe-0,transport=shmem,rateLogging=1" | o2-dpl-raw-parser -b --input-spec "A:FT0/RAWDATA"
```

- Start your o2 dpl with raw-reader as data source:

```
o2-raw-file-reader-workflow --delay 1 -b --conf run_raw_reader.cfg | o2-your-dpl-workflow -b
```

run_raw_reader.cfg:

```
#[defaults]
#dataOrigin = FT0
#dataDescription = RAWDATA

[input-0]
dataOrigin = FT0
dataDescription = RAWDATA
filePath = /home/fitdaq/work/data_raw_reader/ft0_20200521.raw
#filePath = /home/fitdaq/work/data/ft0raw.bin
```



Backup slides

Readout(DataAggregator and ConsumerFairMQ) data flow schematics



Software(logic) level

Consumer FairMQchannel
(one superpage -> one FairMQmessage)

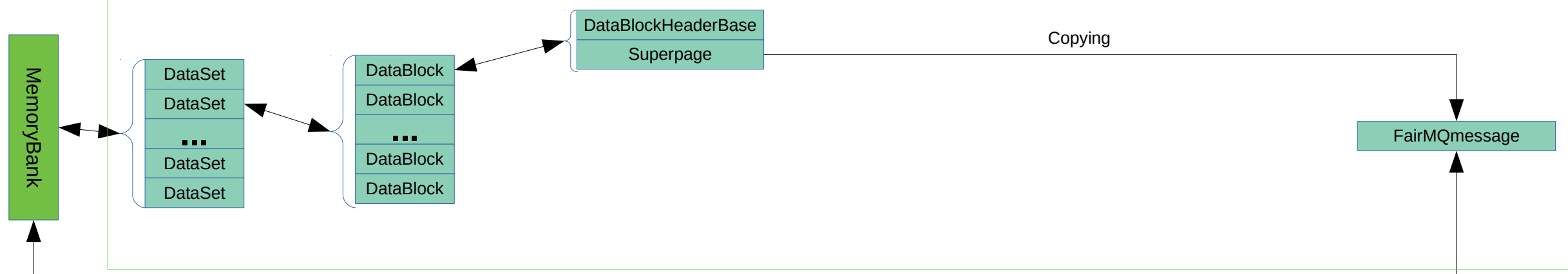

Hardware(physical) level



Readout(DataAggregator and ConsumerFairMQ) data flow schematics



Software(logic) level

Consumer FairMQchannel
(one superpage+stfHeader -> one FairMQparts)

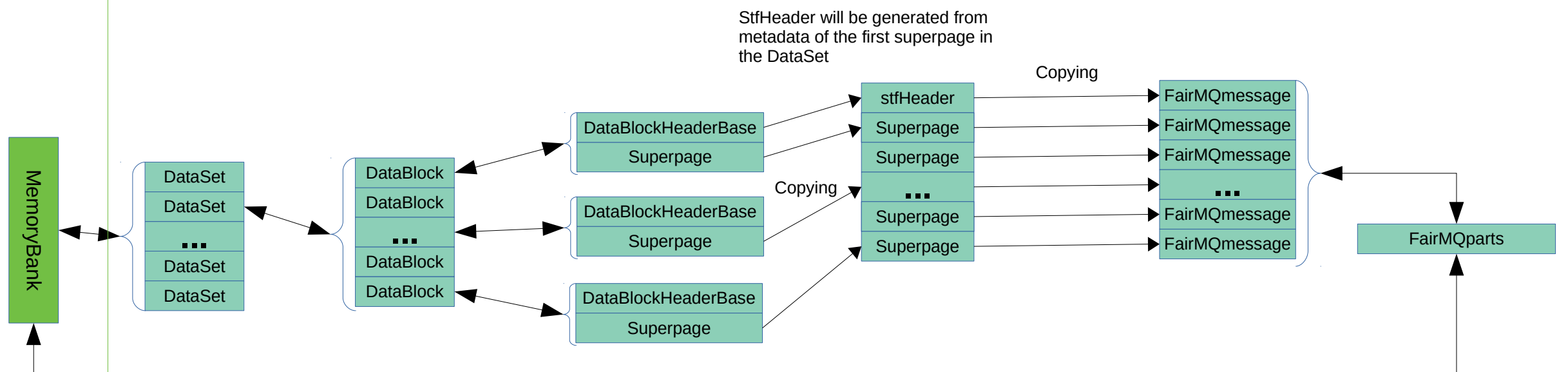

Hardware(physical) level

