

Status of MUonE experiment

Marcin Kucharczyk

IFJ PAN

Seminarium IFJ PAN
30.04.2026



Outline



- a_μ : theory vs experiment
- How to measure hadronic contribution to a_μ
- Proposal of the MUSE experiment
- MUSE detector
- Test Runs & plans
- MUSE group from IFJ PAN

Anomalous magnetic moment of muon

Magnetic moment $\vec{\mu}$ is proportional to its spin ($c = \hbar = 1$)

$$\vec{\mu} = g \left(\frac{e}{2m} \right) \vec{S}$$

Landé *g*-factor predicted from Dirac equation $g = 2$ for *pointlike* fermions

In reality: $g > 2 \rightarrow$ **anomalous magnetic moment** $a_\mu = \frac{g-2}{2}$

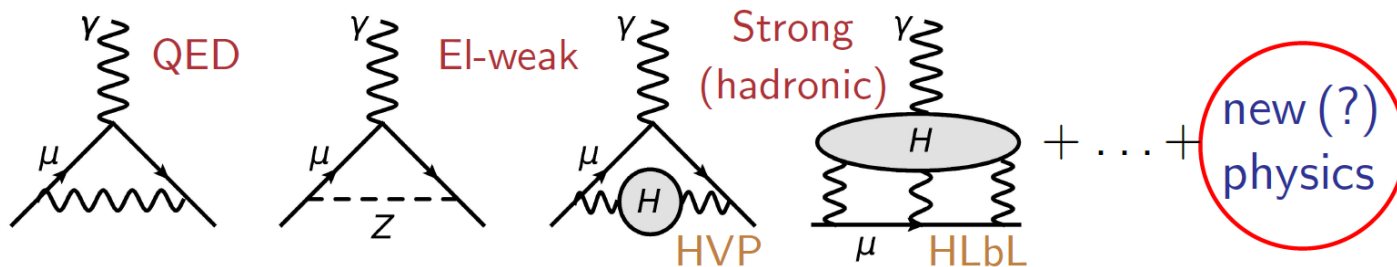

HVP - Hadronic Vacuum Polarization
HLbL - Hadronic Light-by-Light scattering

$$a_\mu = a_\mu^{QED} + a_\mu^{EW} + a_\mu^{QCD} + a_\mu^{NP}$$

a_μ - excellent probe of SM and BSM

Hadronic contribution to a_μ

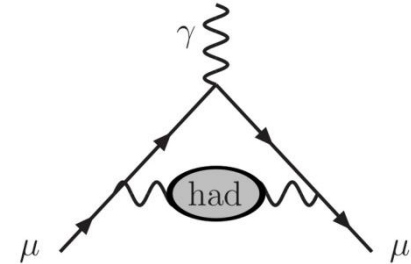

Hadronic effects: **HVP, HLbL**

- main source of uncertainty of theoretical prediction of a_μ
- predominant correction from hadronic LO contribution

- QED corrections known to 5 loops
- EW known to 2 loops
- **Hadronic - non-perturbative QCD**

0.006% of a_μ^{SM}
 99.8% of $\sigma(a_\mu^{\text{SM}})$

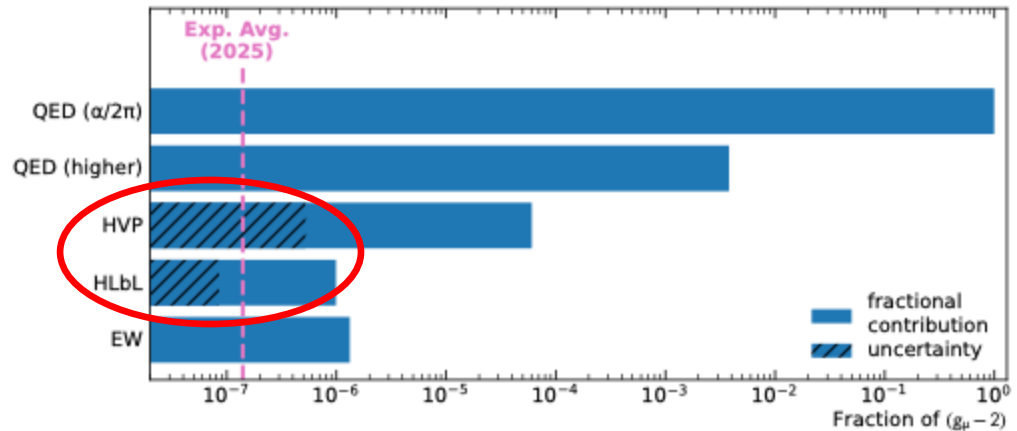

Data-driven methods used to determine hadronic vacuum polarization contribution

- determined from $e^+e^- \rightarrow \text{hadrons}$
- dispersion relation + experimental cross-section e^+e^- (and τ) \rightarrow hadrons

[Phys. Rev. Lett. 126 (2021) 141801]

Contribution	Value [10^{-11}]	σ	σ / σ_{total}
QED (5 loops)	116,584,718.931	0.104	0.001%
EW (2 loops)	153.6	1.0	0.2%
HVP (non-pert.)	6,845	40	99.8%
HLbL (non-pert.)	92	18	
Total SM	116,591,810	43	100%

Measurements of hadronic contribution to a_μ



Theory calculations of a_μ based on **dispersion relation** to determine LO hadronic vacuum polarization contribution

$$a_\mu^{\text{HLO}} = \frac{\alpha_0^2}{3\pi^2} \int_{4m_\pi^2 c^4}^{\infty} ds K(s) \sigma^{(0)}(s)$$

[Phys. Rev. D 97 (2018) 114025]

$\sigma^{(0)}$ → total x-section $e^+e^- \rightarrow \text{hadrons}$
kernel function $K(s) \sim 1/s$

$\sigma(e^+e^- \rightarrow \text{hadrons}) \Rightarrow$ timelike processes

- $\sigma(0)$ – measurements from many different experiments (BESIII, CMD3, BaBar, KLOE, VEPP-2000)
- low-energy region affected by hadronic resonances and particle production threshold effects
- accuracy $\sim 0.6\%$

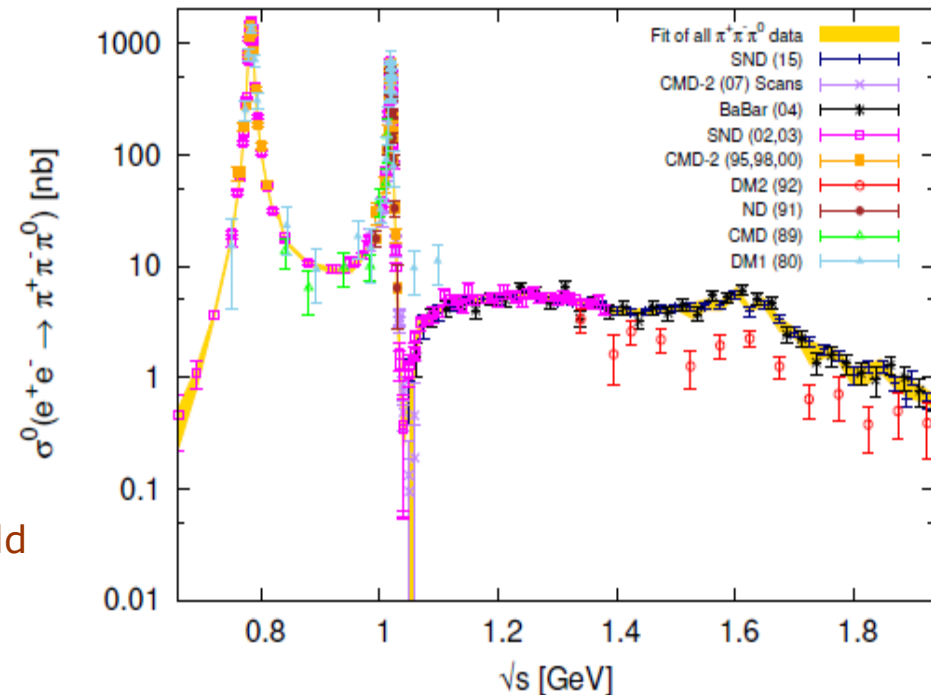

Tension between data-driven and lattice determinations of SM prediction of a_μ

Current status of muon g-2

[FERMILAB-PUB-25-0364-PPD]

- experimental average:
Fermilab + BNL ($\sigma = 124$ ppb)
 ppb - parts per billion
- theory prediction with dispersive relation
 ($> 5\sigma$)
- lattice QCD from Theory Initiative White Paper (2025)
 ($< 1\sigma$)
- new result with CMD-3 data on $\sigma(e^+e^- \rightarrow \text{hadrons})$
 ($< 1\sigma$)

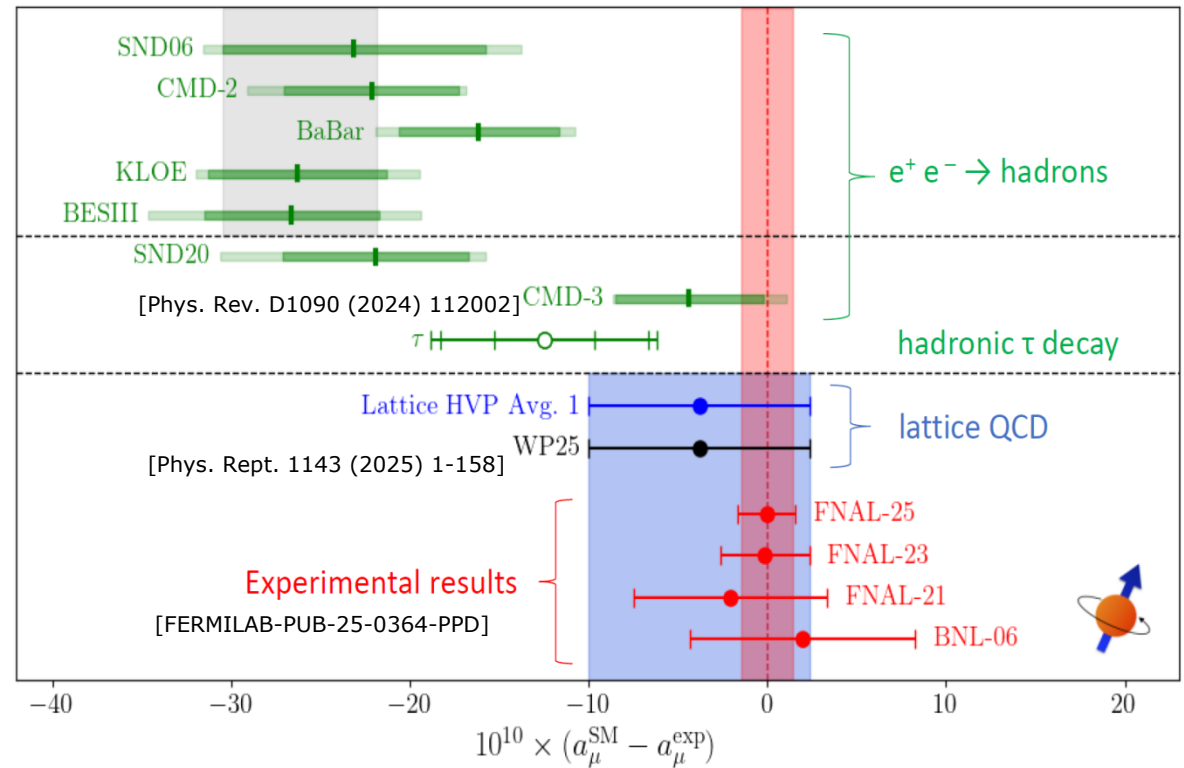

Unexplained tension between bulk of experimental results and outlier CMD-3 result (?)

Lattice QCD results in disagreement with most of calculation based on dispersion relation

→ can we experimentally test the lattice calculations (?)

MUonE aims at independent direct measurement of a_μ^{HLO}

MUonE approach to measure a_μ^{HLO}

A novel method exploits space-like integral

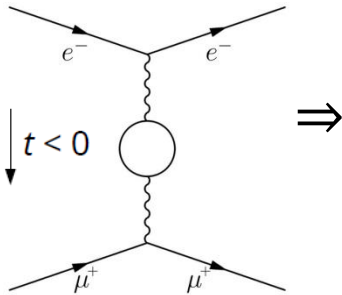

$$a_\mu^{HLO} = \frac{\alpha_0}{\pi} \int_0^1 dx (1-x) \Delta\alpha_{\text{had}}[t(x)] \quad (*)$$

$t(x) = q^2(x) = x^2 m_\mu^2 c^4 / (x-1)$ is the squared 4-momentum transfer

$\Delta\alpha_{\text{had}}(t)$ is the hadronic contribution to the running of $\alpha(t)$

$\alpha_0 = e^2 / \hbar c$ is the fine structure (or Sommerfeld's) constant

- measure hadronic contribution to running fine-structure constant
- determine of a_μ^{HLO} from scattering $\mu + e \rightarrow \mu + e$ data

Hadronic and leptonic contribution to running fine-structure constant

$$\alpha(t) = \frac{\alpha_0}{1 - (\Delta\alpha_{\text{lep}}(t) + \Delta\alpha_{\text{had}}(t))}$$

- hadronic contribution $\Delta\alpha_{\text{had}}(t)$ extracted from the shape of $\alpha(t)$
→ in the space-like region $x \in (0-1)$ and $t(x) < 0$
- leptonic contribution well known from perturbative calculations
- a_μ^{HLO} evaluated via sum rule in eq. (*)

MUonE approach to measure a_μ^{HLO}



[Phys. Lett. B746 (2015) 325]

Fine-structure 'constant' α runs with energy scale because of radiative corrections, where all but hadronic part is known well theoretically

Main advantage

- $\Delta\alpha_{\text{had}}(t)$ is well behaved, smooth function
- free of resonances (in contrast to the dispersive integral)
- low-energy enhancement
 - peak of the integrand at $x \sim 0.9, t = -0.11 \text{ GeV}^2$
 - $\Delta\alpha_{\text{had}}(t_{\text{max}}) \sim 10^{-3}$

Experimental data on t -channel processes needed:

- space-like contribution to Bhabha scattering
- **fully space-like μ -e elastic scattering!**

Measure differential cross-section as a function of t on a range which spans the t_{peak} value

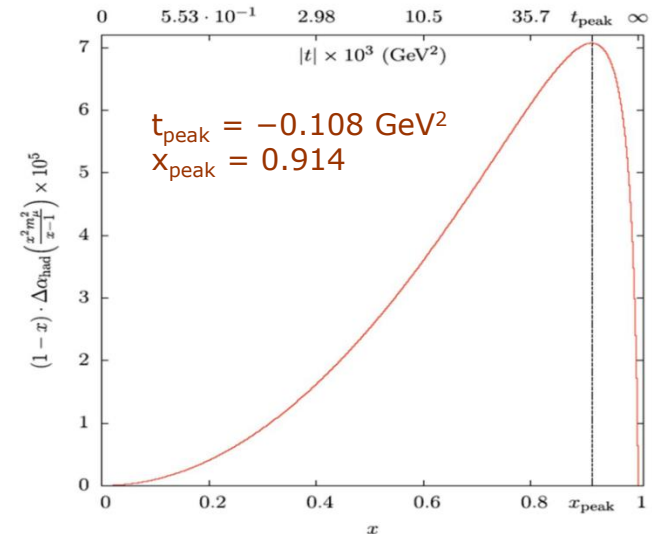
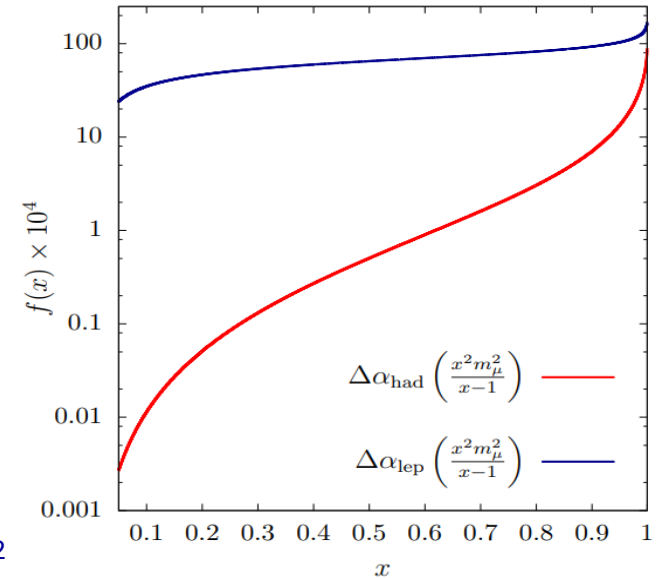

a_μ^{HLO} via muon-electron scattering

[Letter of Intent SPSC-I-252 (2019)]

Elastic scattering of high-energy muons on the atomic electrons in a low-Z target

$$\frac{d\sigma}{dt} \approx \frac{d\sigma_0}{dt} \left| \frac{\alpha(t)}{\alpha(0)} \right|^2 \approx \frac{d\sigma_0}{dt} \left| \frac{1}{1 - \Delta\alpha(t)} \right|^2$$

running of α

Running of fine-structure constant can be extracted from differential x-section for μ - e elastic scattering

$$\Delta\alpha(t) = \Delta\alpha_{lep}(t) + \Delta\alpha_{had}(t)$$

$d\sigma_0/dt$ - effective Born cross section

measurement

$$R_{had}(t) = \frac{d\sigma_{data}(\Delta\alpha_{had} \neq 0)}{d\sigma_{MC}(\Delta\alpha_{had} = 0)} \approx 1 + 2\Delta\alpha_{had}(t)$$

simulation

To be measured

Elastic events selected using correlated track angles

- angular measurement: extract $\Delta\alpha_{had}(t)$ from 2D distribution (θ_μ, θ_e)
- correlation between θ_μ and θ_e allows to select elastic events and reject background (mainly from $\mu N \rightarrow \mu N e^+e^-$)

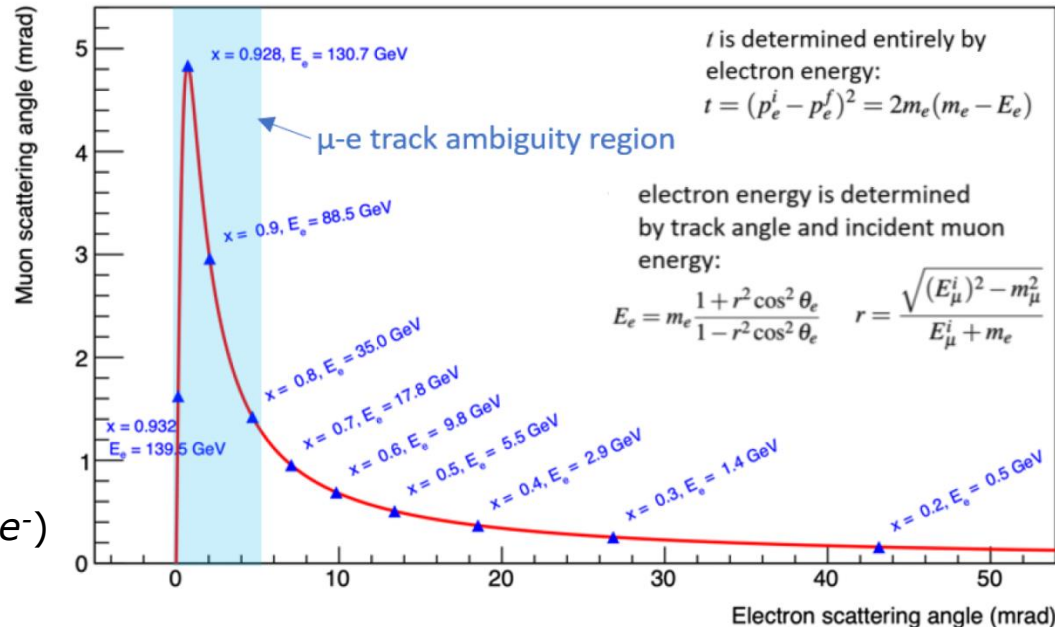
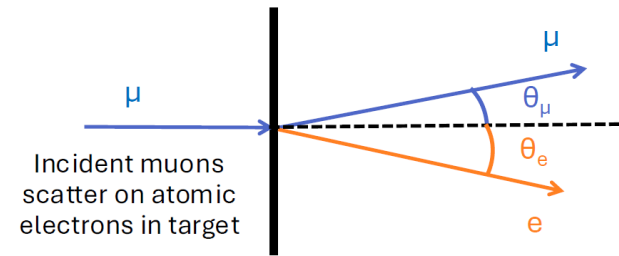

MUonE experiment



[Letter of Intent SPSC-I-252 (2019)]

CERN SPS 160 GeV muon beam M2 ($1.3 \times 10^7 \mu/s$)

Located between Beam Momentum Station and COMPASS

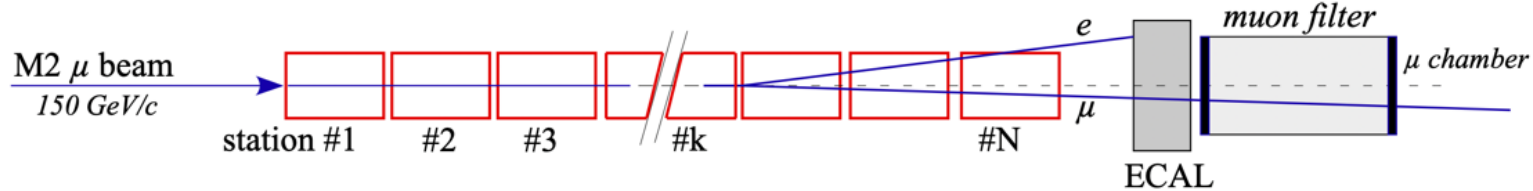

~3 years post LS3 (>2030)

- integrated luminosity $1.5 \times 10^7 \text{ nb}^{-1}$
- M2 beam-line
- precision goal $\Delta\alpha_{\text{had}}$ to $<0.5\%$

40 modular tracking stations, each comprising:

- ~2cm target of low-Z material (Be or C)
→ to minimize distortions of outgoing e/ μ tracks
- 6 tracking modules

ECAL & Muon Filter for e/ μ separation

Boosted kinematics

- $\theta_e < 32\text{mrad}$ (for $E_e > 1 \text{ GeV}$)
- $\theta_\mu < 5\text{mrad}$

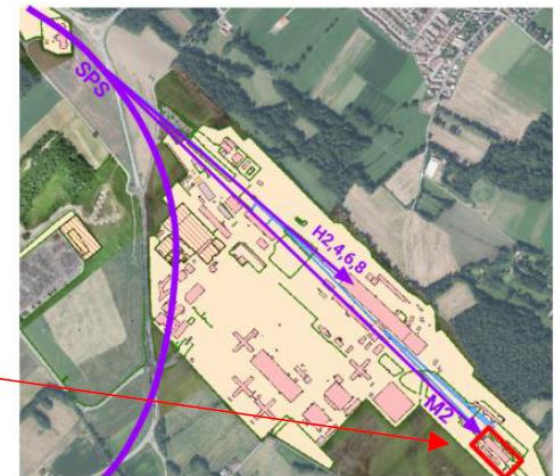
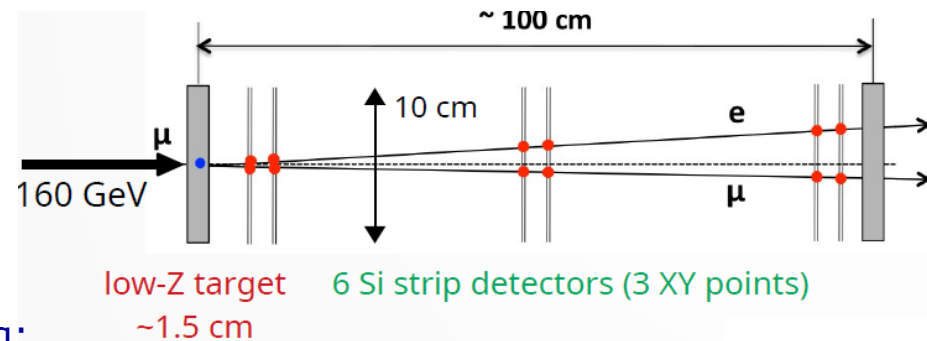

EHN2 in SPS NA
upstream
AMBER/COMPASS

MUonE tracking system



[Letter of Intent SPSC-I-252 (2019)]

MUonE tracking station

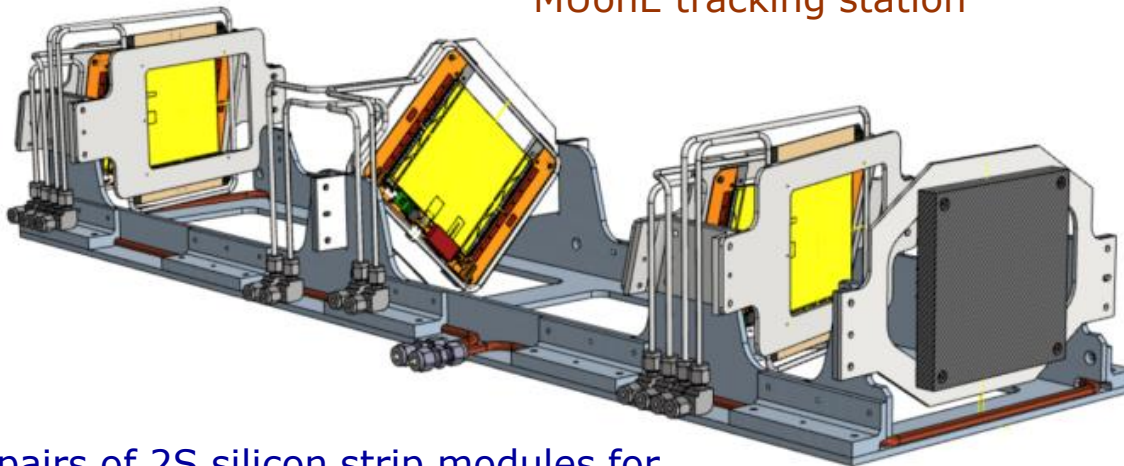

- $10 \times 10 \text{ cm}^2$ active area
- $320 \text{ }\mu\text{m}$ thickness
- 40 MHz, binary readout
- $90 \text{ }\mu\text{m}$ strip pitch
- $\sim 26 \text{ }\mu\text{m}$ nominal spatial resolution

[CMS-CR-2023-146]

3 pairs of 2S silicon strip modules for CMS Phase-2 (HL-LHC) outer tracker upgrade

- 2 tilted pairs for x - y coordinates to reduce effective strip pitch and improve spatial resolution
- 1 pair (u, v coords) to solve ambiguities
- expected angular resolution $\sim 0.02 \text{ mrad}$

Challenge is to control systematic effects at the level of statistical one (10 ppm in the signal region)

- angular intrinsic resolution
- multiple scattering ($< 1\%$)
- longitudinal alignment ($< 10 \text{ }\mu\text{m}$)
- knowledge of the beam energy (few MeV) - BSM

CMS 2S module

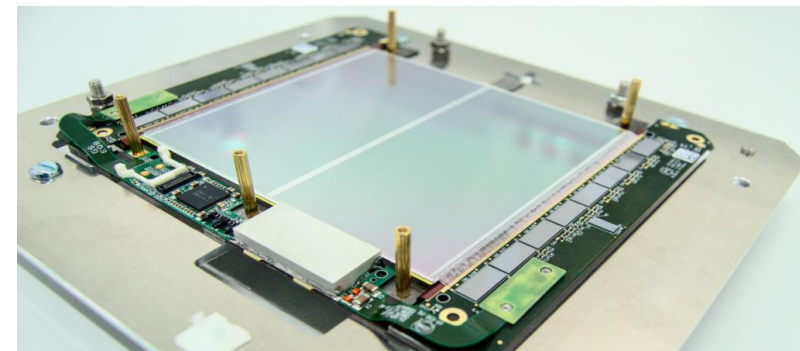

25 lead tungstate (PbWO_4) crystals (used in CMS ECAL)

- (2.85 cm) x (2.85 cm) cross section
- 23 cm long ($\sim 26 X_0$)
- light readout with APDs directly coupled to the crystals
- calibrated with a fiber-coupled laser system
- measures 1-150 GeV electron energies
- energy resolution $< 5\%$
- filters inelastic events by verifying energy deposition inferred from track angles
- to be enlarged in final 40-station setup (1 m) x (1 m)



prototype tested during 2025 Test Run

Breaks muon/electron track angle ambiguity

Filters inelastic events by verifying energy deposition inferred from track angles

2017: dedicated test beam to study multiple scattering [JINST 15 (2020) P01017]

2018: study elastic scattering properties and event selection [JINST 16 (2021) P06005]

- first complex proof of concept performed downstream COMPASS
- beam rate of few kHz
- clean sample of elastic events obtained

2022 / 2023: test 2 tracking stations & ECAL

- M2 muon beam in the CERN North Area
- 160 GeV beam at 40 MHz, $\sim 10^8$ elastic events collected
- stations with thin graphite target and 6 tracking modules
- aimed at testing DAQ, tracking/vertexing, FPGA processing, sensor alignment

2025: run with scaled version of the complete apparatus (3-month run)

- 3 stations + ECAL + Muon Filter
- Beam Momentum Spectrometer (BMS) integrated
- basis for full-scale proposal (40 stations) post LS3
- data analysis ongoing

Test Run 2018

[JINST 16 (2021) P06005]



- Setup located downstream COMPASS
- Aim of the measurement campaign
 - muon-electron elastic scattering with high statistics
- Using muons from pions decays (*hadron beam*)
 - estimated beam momentum $p_{beam} = (187 \pm 7)$ GeV
- Measure correlation between the scattering angles
 - muon angle vs the electron angle
- Electron energy vs electron angle correlation and PID
- Detector
 - tracking system (*dev. for INSULab telescope*):
 - 16 stations equipped with AGILE silicon strip sensors
 - 400 micron thick, single sided, about 40 micron intrinsic hit resolution
 - electromagnetic calorimeter: 3x3 cell matrix, BGO-PMT crystals, $\sim 8 \times 8$ cm²

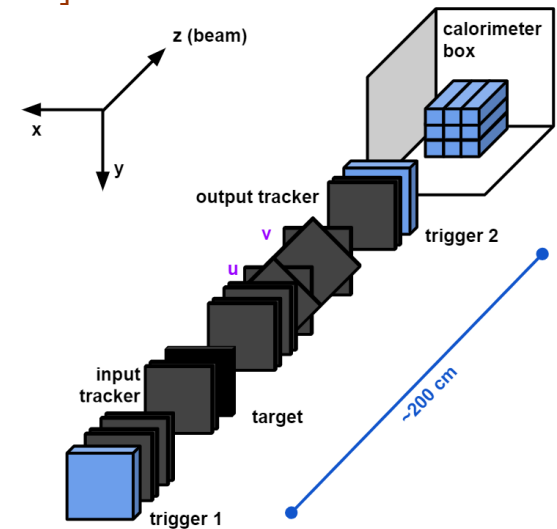

Test Run 2018 - results

[JINST 16 (2021) P06005]

- Aimed mainly to explore the ability to select a clean sample of elastic scattering events in view of designing the final experiment
 - able to select clean sample even if the resolution worse than the one planned to be used in MUonE
 - first results of this kind
- Importance of an adequate calorimeter
 - understand the electrons emitted in the range of a few GeV
 - determine the behaviour of the background
- Important upgrade of Geant4
 - accurate angular distribution of the electrons of the pair implemented
 - Geant4 version 10.7
(already implemented in MUonE software)

Conclusion: able to select clean sample of elastic events

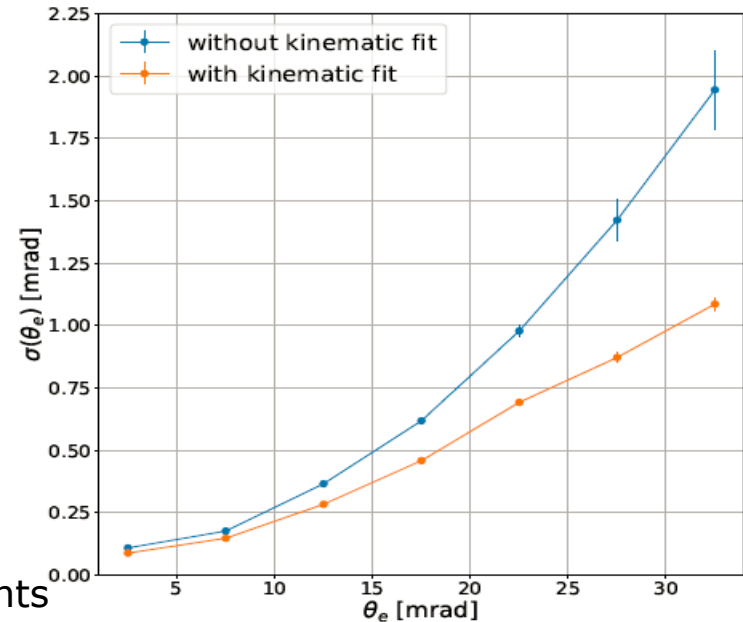
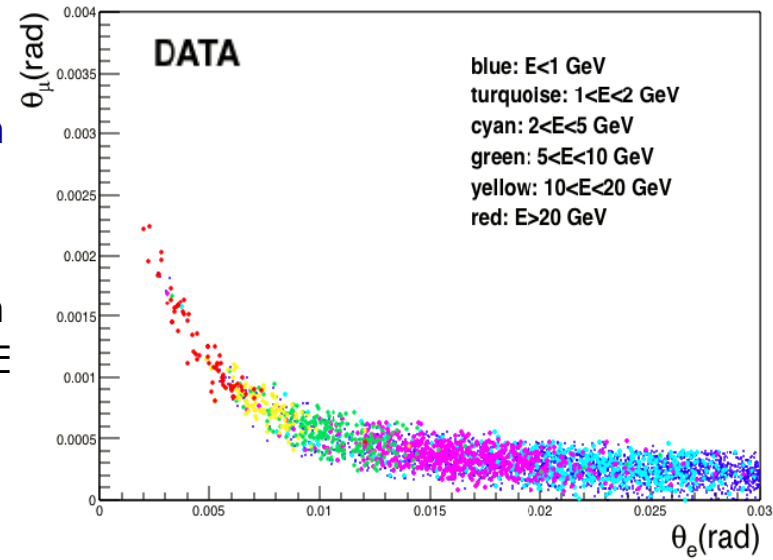

Test Run 2025

Phase 1 of the MUonE experiment - small scale version of full experiment

[CERN-SPSC-2024-015; SPSC-P-370]

July-August 2025: test run at CERN M2 beamline with 160 GeV muons

- demonstrate detection integration
- validate DAQ chain
- demonstrate elastic event identification

Fully equipped for the first time

- 3 tracking stations + ECAL + Muon Filter prototype
- Beam Momentum System (BMS) prototype
- fully configured Serenity-based DAQ (40 MHz)

Goal: preliminary measurement of $\Delta\alpha_{\text{had}}$ to 20%

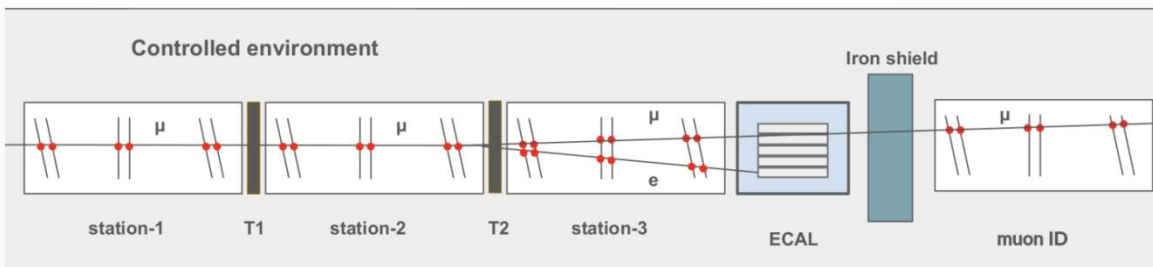
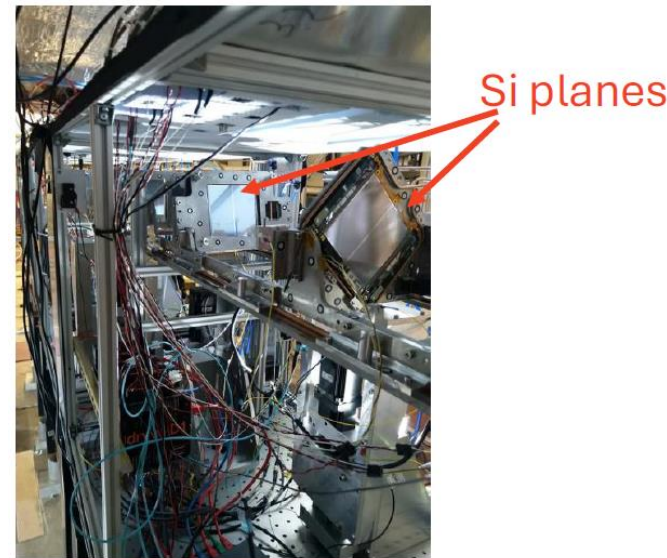

Test Run 2025



Test Run 2025 – preliminary results

Tracker-only analysis of elastic events

Elastic events from both targets

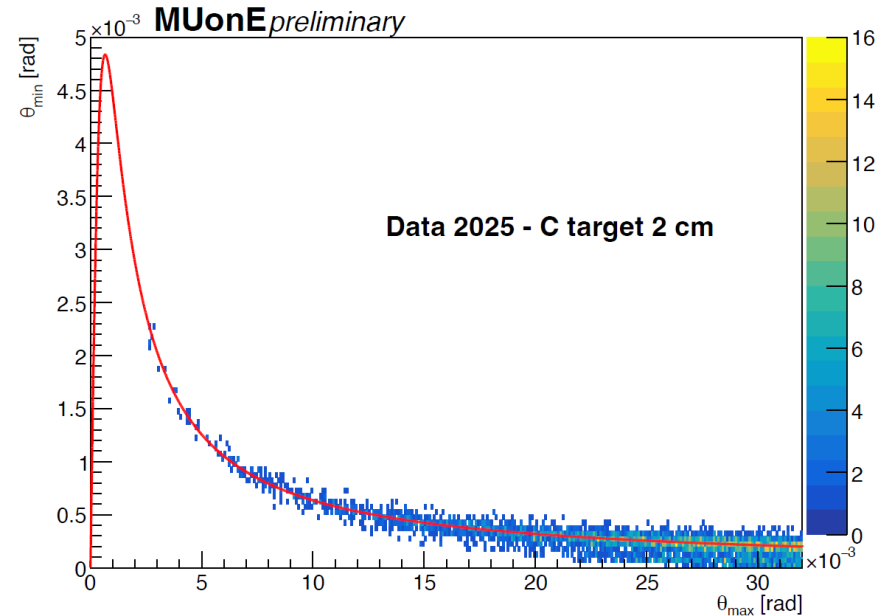
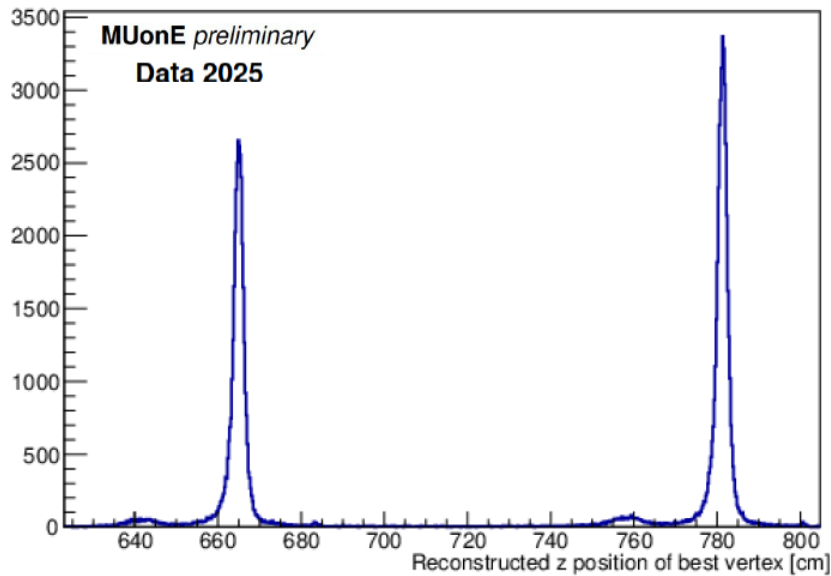

Ongoing analysis campaign

- study systematic effects
- preliminary measurements of at $\sim 20\%$ level (syst. & stat.)

Experimental groups

INFN Pisa

INFN Bologna

INFN Padova

INFN Università di Perugia

INFN Università di Trieste

IFJ PAN Kraków

University of Rijeka

Imperial College London

Liverpool University

J. Gutenberg Universität Mainz

University of Virginia

Regis University

Northwestern University

Cornell University

Peking University

Shanghai Jiao Tong University

Theoretical groups

Università di Padova

Università di Pavia

Paul Scherrer Institute

Universität Zürich

ETH Zürich

Group from IFJ PAN Kraków [5 staff, 2 PhD]:

Marcin Kucharczyk (*group leader*)

Mariusz Witek

Mateusz Goncerz (*PhD thesis partially on MUonE*)

Miłosz Zdybał (*PhD thesis partially on MUonE*)

Marcin Wolter

Izabela Juszczyk (*PhD student*)

Damian Mizera (*PhD student*)

+ few MSc students

NCN OPUS 23 2022/45/B/ST2/00318

"Poszukiwanie Nowej Fizyki w eksperymencie MUonE"

Main contributions

- central software
- detector simulation
- data analysis
- global alignment
- machine learning based tracking and PID

Main publications with dominant contribution from IFJ PAN

- [JINST 16 \(2021\) P06005](#)
Muon-electron elastic scattering in 2018 test beam
- [Computer Science 25\(1\) \(2024\) 25-46](#)
Machine learning based event reconstruction for MUonE
- [Computer Science 20\(4\) \(2019\) 477-493](#)
Track finding with deep neural networks for MUonE

Cover costs of high- and low-voltage equipment for trackers in Test Runs

Involvement in LoI [[CERN-SPSC-I-252](#)] & proposal for MUonE Phase 1 [[CERN-SPSC-2024-015](#)]

IFJ PAN contribution to central software



development / implementation / maintenance

- Central MUonE software based on FairRoot algorithms for all crucial stages of data analysis:
 - pattern recognition
 - track and vertex reconstruction (kinematic vertex fit)
 - detector simulation
 - detector global alignment
 - offline selection
 - implementation of MC generators (e.g. MESMER)

Official MUonE software successfully used e.g. to perform analysis of data collected during 2018/2023/2025 test-runs

- Data analysis for all test-runs
- Data processing and MC production for 2025 analysis
- Machine learning based event reconstruction for MUonE
 - local GPU server
 - CNN/DNN/GNN based pattern recognition & tracking
 - machine learning based PID
 - machine learning based detector alignment

[JINST 16 (2021) P06005]

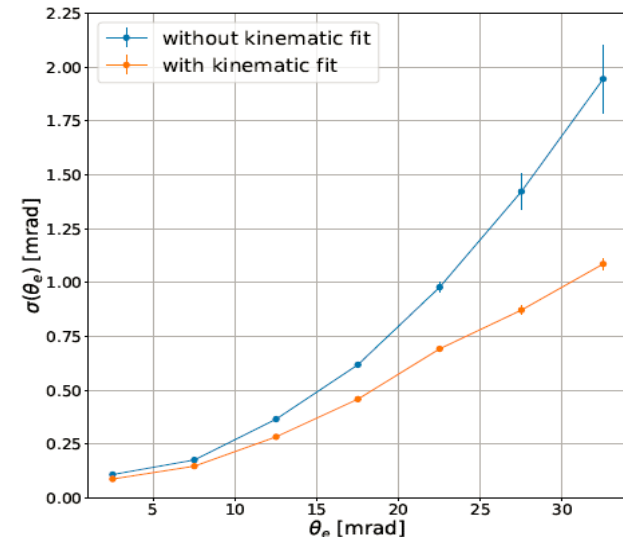
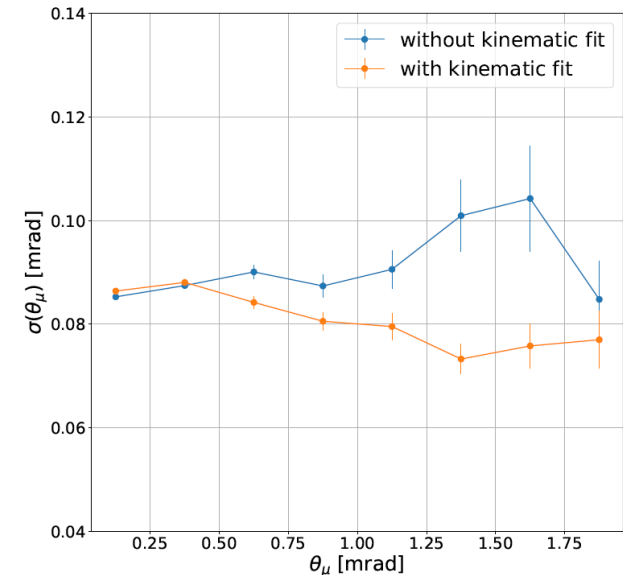

Deep Machine Learning for MUonE online



To be applied to the trigger
(pattern rec. & tracking)

- Idea: **SPEED UP PATTERN RECOGNITION**
 - output is 3D regardless of 2D (x-z, y-z) inputs
- Input: all hits concatenated,
 - no distinction between X, Y and stereo layers
- Ground truth: MC track slope parameters
- Model
 - PyTorch
 - 6 linear layers
 - up to 2000 neurons per layer
- Loss function
 - MSELoss from PyTorch – uses difference between predicted slope parameters and ground truth

[Computer Science 20(4) (2019) 477-493]
[Computer Science 25(1) (2024) 25-46]

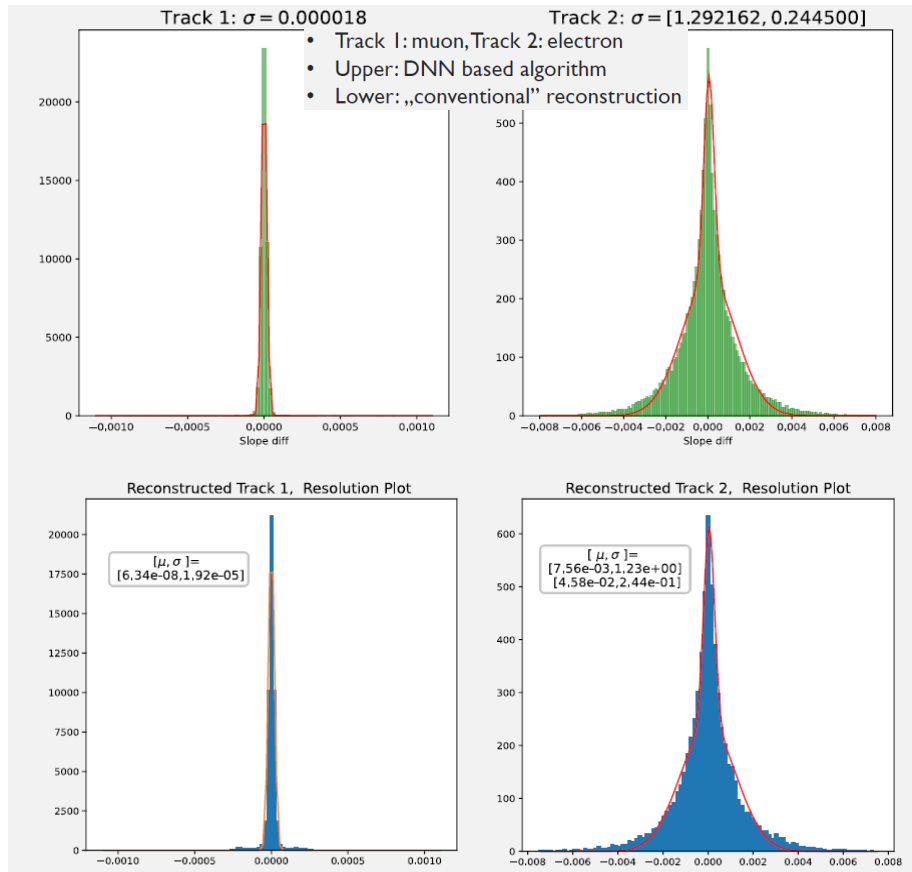

Particle	DNN based	Classical
Muon	$\sigma = 0.000018$ mrad	$\sigma = 0.000019$ mrad
Electron	$\sigma_1 = 1.290$ mrad, $\sigma_2 = 0.245$ mrad	$\sigma_1 = 1.230$ mrad, $\sigma_2 = 0.244$ mrad

GNN based tracking for MUonE

see presentation by Damian on Epiphany 2026
<https://indico.cern.ch/event/1594628/sessions/633728/#20260113>

Graph Neural Networks (GNN) for pattern Recognition

→ full 3D approach

→ main advantage: track reconstruction despite missing hits

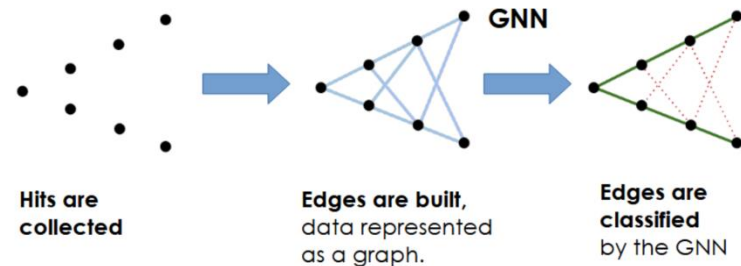

Data

- **Setup:** 3 tracking stations (xy-uv-xy configuration) as in 2025 test run
- **Inputs:** No 3D hits → 2D strips only (x-z and y-z projections)
- **Edges:** connected across consecutive layers
network implicitly learns geometry and orientations

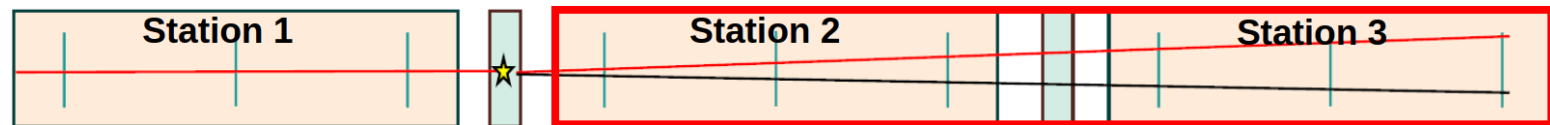

Architecture (PyTorch)

- Framework: Message-Passing GNN
- Node Network: 2-layer MLP (128 nodes/layer)
- Edge Network: 2-layer MLP (256 nodes/layer)
- Training: 500 epochs for full convergence

**Under review in Acta
Physica Polonica B**

MLP - MultiLayer Perceptron (node encoder)

GNN based tracking for MUonE

- Graph Construction:

- hits as vertices
- edges connect adjacent layers
- orientation is learned implicitly

- Training:

- simulated MUonE data (80/20 split)
- classify true vs. false track fragments

- Performance:

- edge classification accuracy: ~ 99.4%

- Error Analysis:

- ambiguities mainly arise from spatially close hits
(in first two layers after the target)

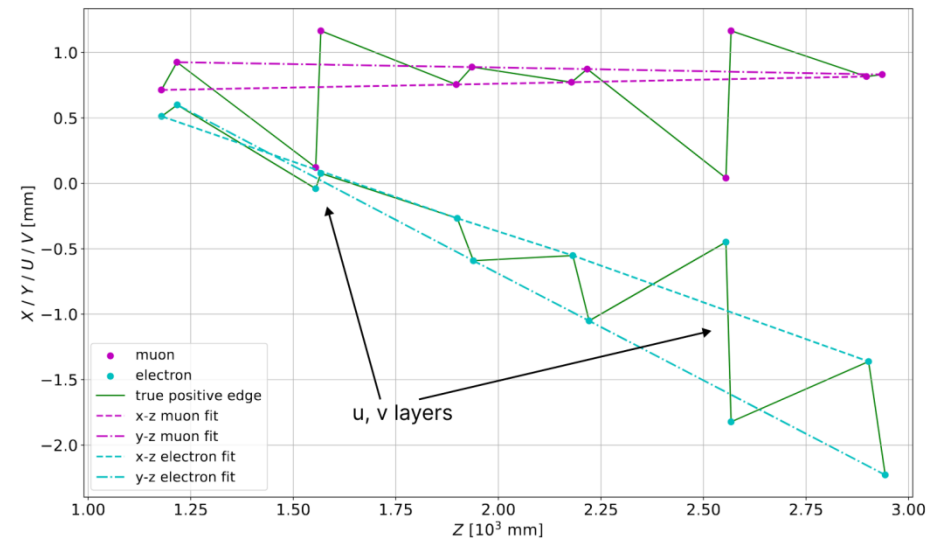
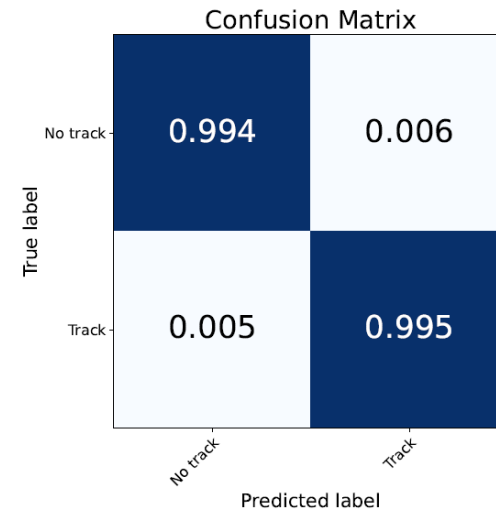

BSM at MUonE



Detector sensitive to long-lived exotic particles, which decay between the target and the first tracking module, e.g. dark matter photons:

$$\mu + e \rightarrow \mu + e + A'(\rightarrow e^+e^-)$$

and covers parts of phase-space unreachable to other experiments

During runs, scheduled after the main measurement goal is achieved, sensitivity to LLPs can be significantly enhanced by adjusting the detector layout → also massive long-lived particles decaying into leptons/heavy quarks

→ very precise reconstruction of the displaced vertex position

3-track search

[arXiv:2202.08843]

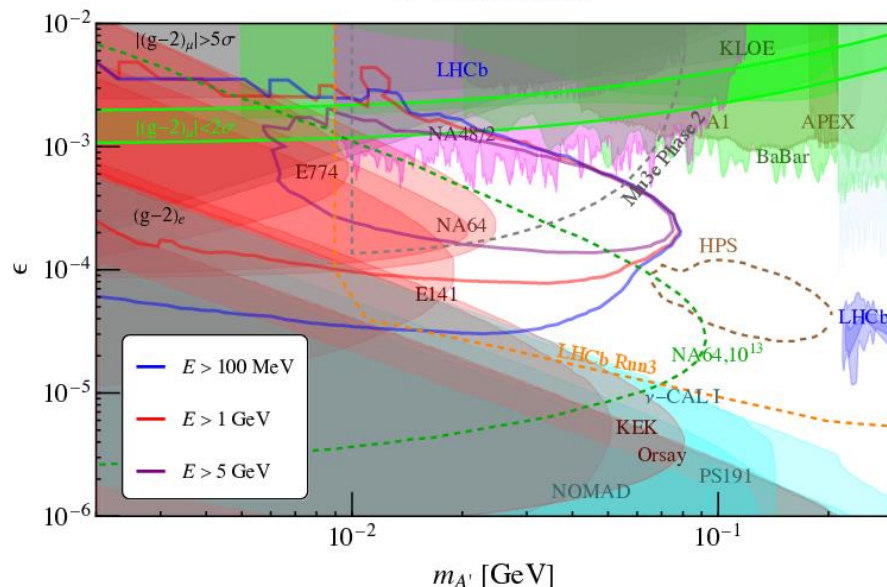

4-track search

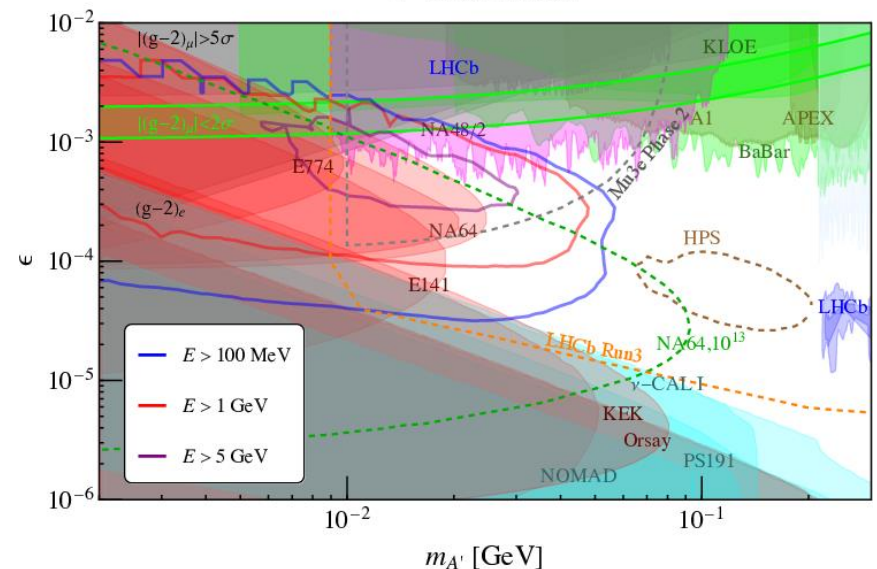

Conclusions

- High precision experimental value of a_μ by Fermilab
- Discrepancy between Lattice vs data-driven
- **MUonE offers independent way to determine a_μ^{HVP}**
 - only opportunity to test experimentally Lattice calculations
- 2025 MUonE test at CERN M2 beamline
 - **validate the concept of experimental setup**
 - study systematic errors and background under realistic conditions
 - preliminary measurement of $\Delta\alpha_{\text{had}}(t)$
- **Long-term goal (after long shutdown 3)**
 - 40 stations \times 3 years of data collection
 - $1.5 \times 10^4 \text{ pb}^{-1}$ integrated luminosity
 - 10 ppm statistical uncertainty
 - **0.1-0.3% on a_μ^{HVP} competitive to other methods**

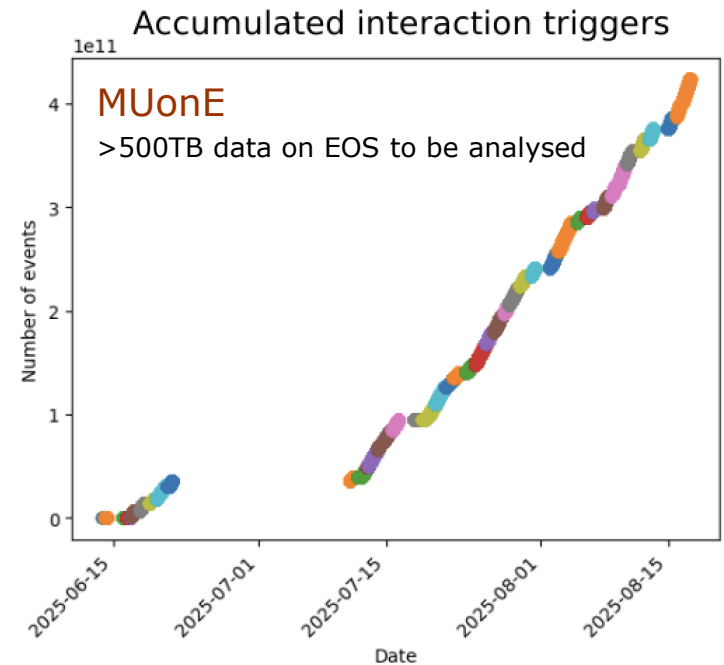

Significant contribution from IFJ PAN group

- development & maintenance of central software
- detector simulation & event reconstruction
- optimization of detector layout (LoI)
- analysis of test beam data
- **development of ML based reconstruction & PID**
- **data processing and MC production**
- partial costs of detector construction for Test Runs