



3RD YEAR DOCTORAL SEMINAR

20 MARCH 2026



THE HENRYK NIEWODNICZAŃSKI
INSTITUTE OF NUCLEAR PHYSICS
POLISH ACADEMY OF SCIENCES

GAMMA-GAMMA TO LEPTON- LEPTON INTERACTIONS IN LHC

USING THE ATLAS FORWARD PROTON DETECTORS

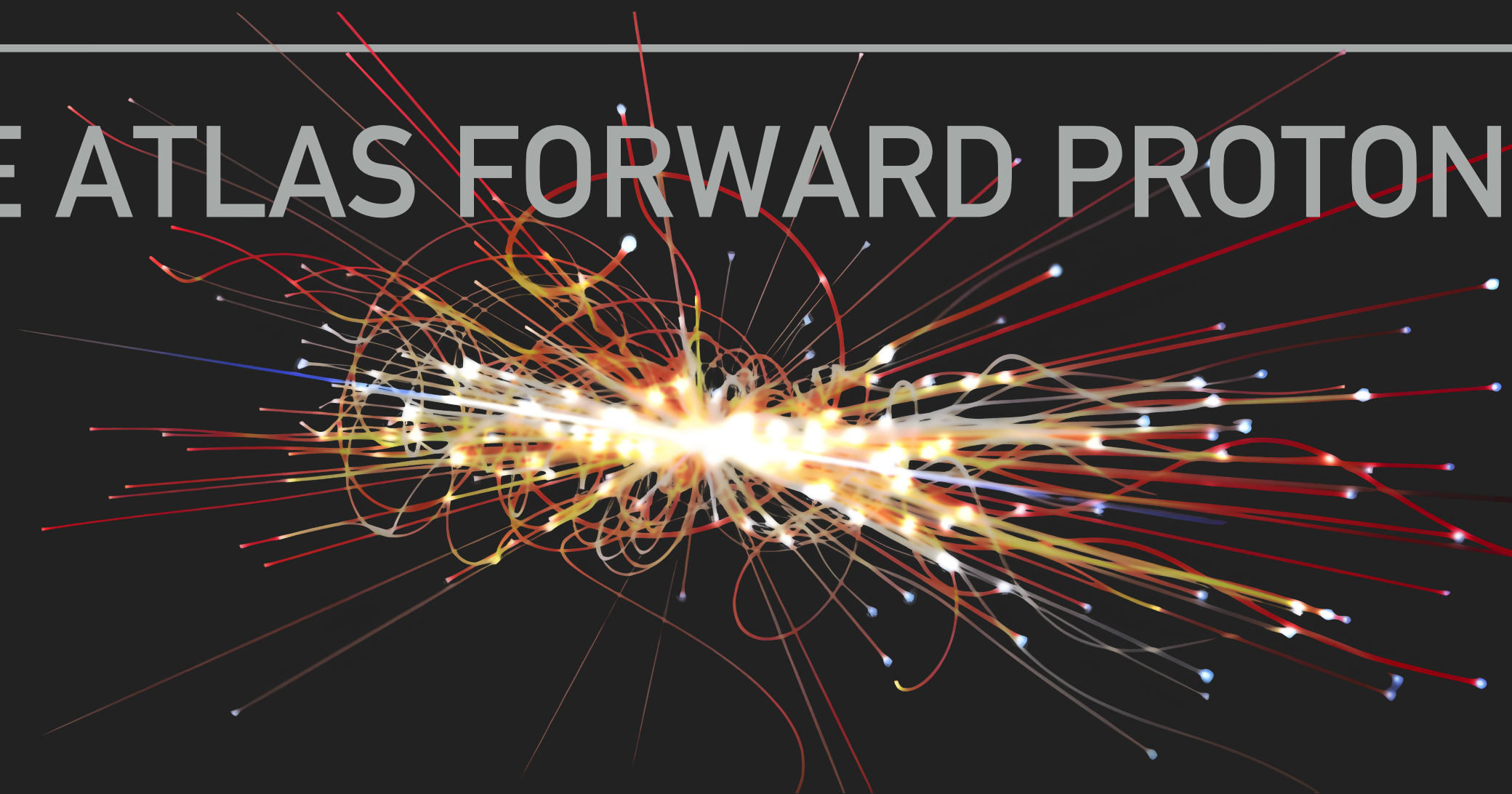

TOMASZ MRÓZ

LHC SUMMARY

- ▶ 100 m deep
- ▶ 27 km circumference
- ▶ 4 interaction points
- ▶ 2 proton/HI beams
- ▶ 13.6 TeV Collision Energy
- ▶ Collision rate 40MHz

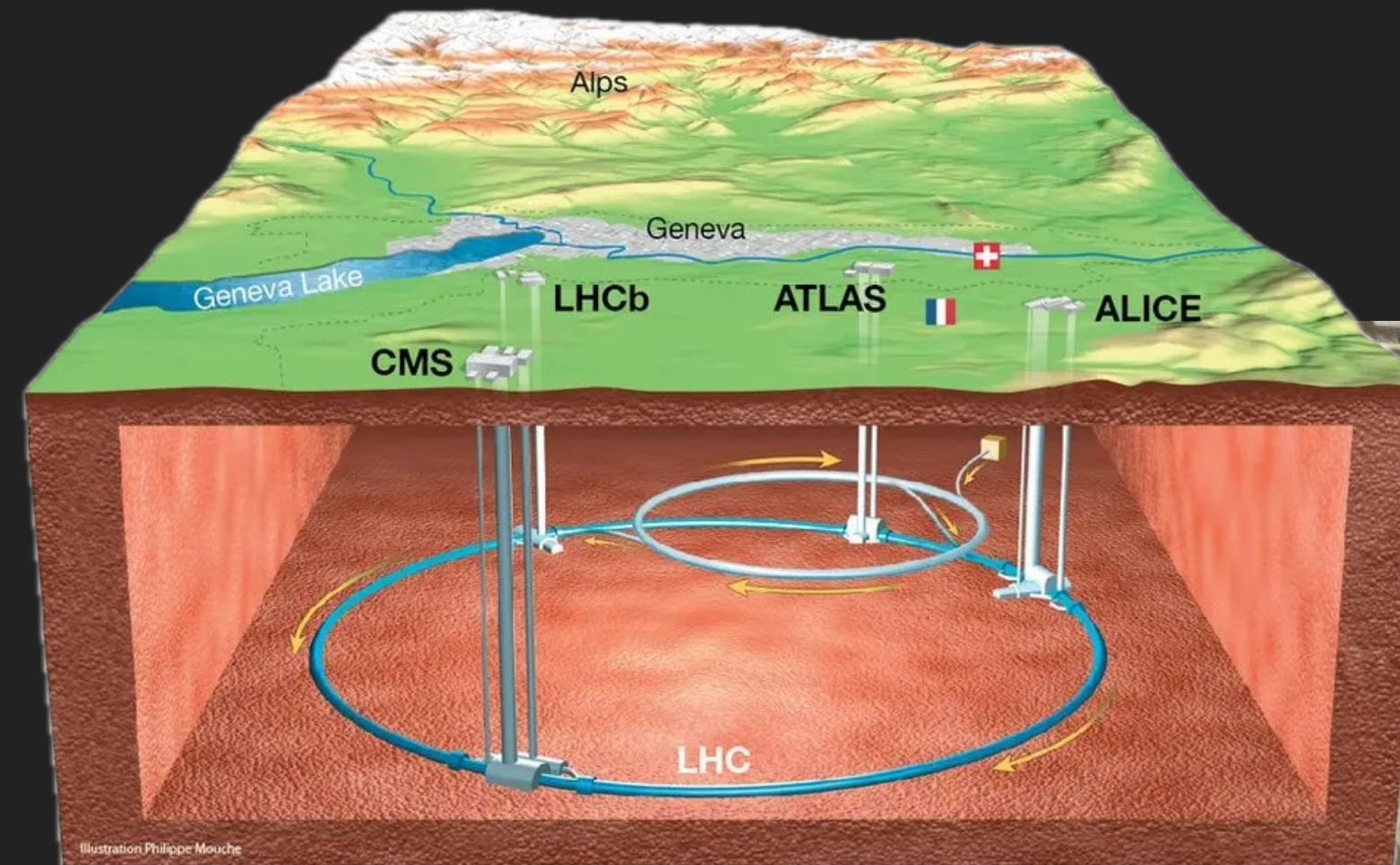

THE HENRYK NIEWODNICZAŃSKI
INSTITUTE OF NUCLEAR PHYSICS
POLISH ACADEMY OF SCIENCES

ATLAS SUMMARY

- ▶ General-purpose experiment
- ▶ Broad physics program: Standard Model tests, Higgs physics, and searches for new physics
- ▶ Largest detector in size ever built
- ▶ Key contribution to Higgs boson discovery (2012)

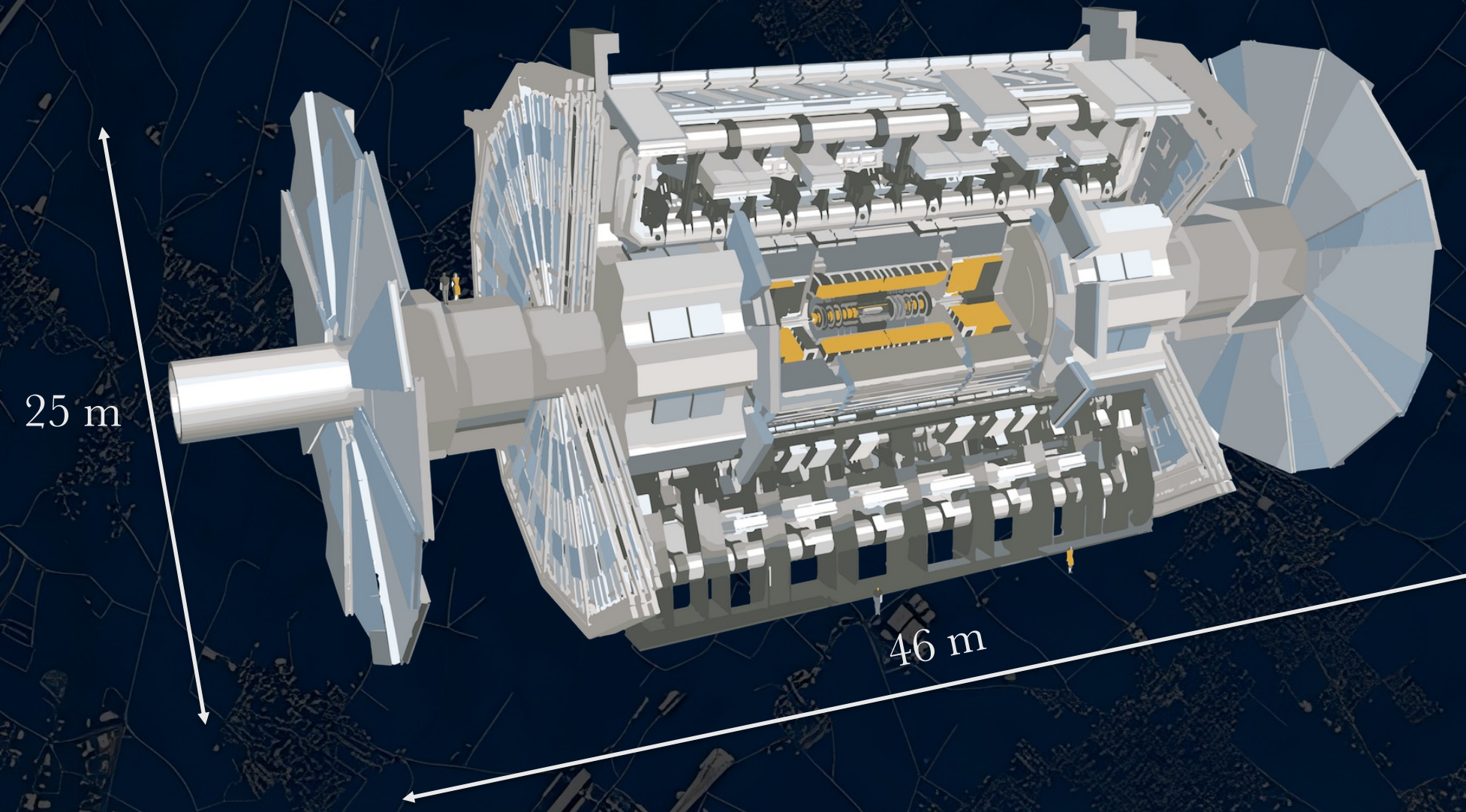

ATLAS Experiment

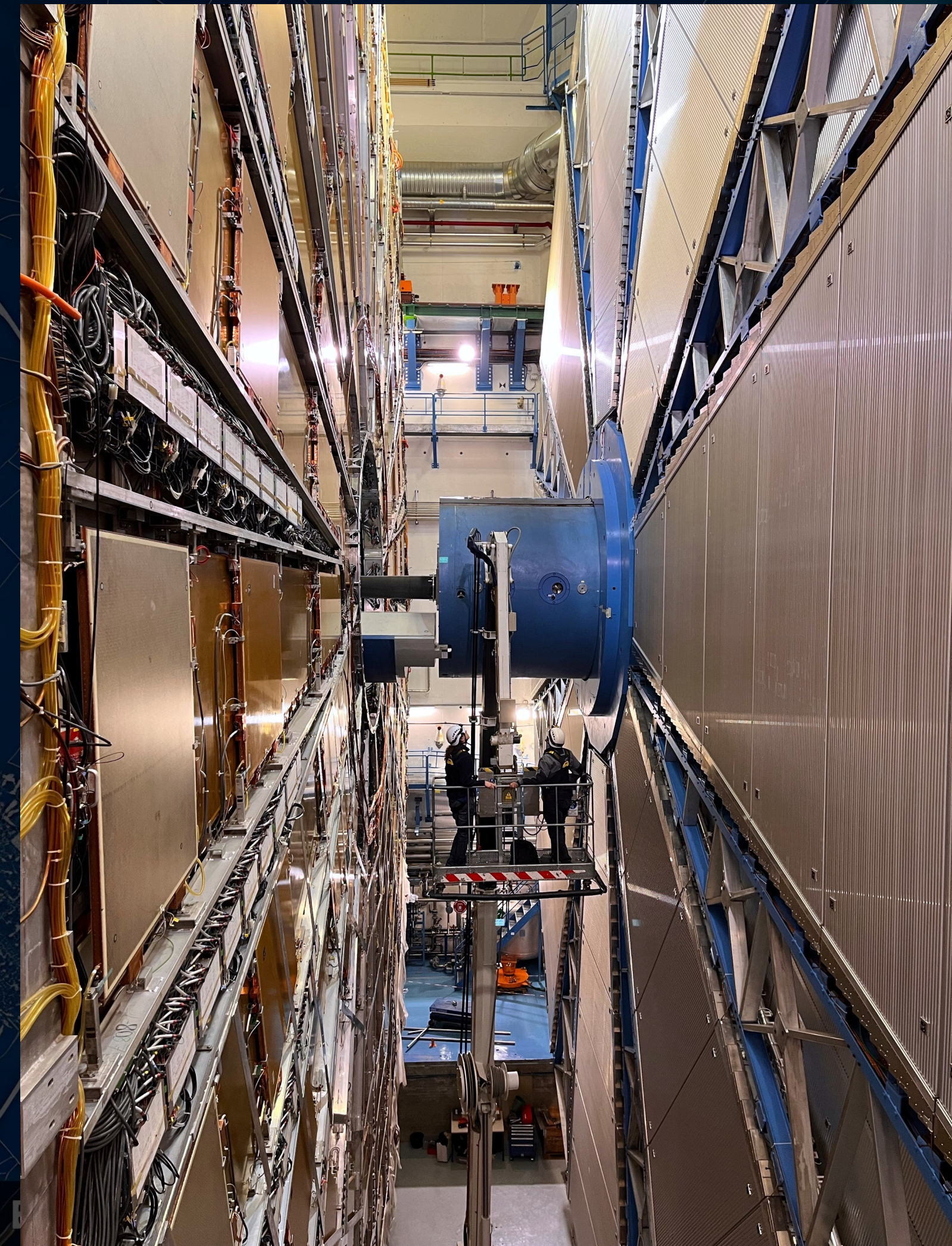

ALICE Experiment

LHCb Experiment



INSIDE OF ATLAS

- ▶ Layered and cylindrical structure
- ▶ Concentric layers arranged radially around the interaction point (IP)
- ▶ Each layer has a distinct physics role

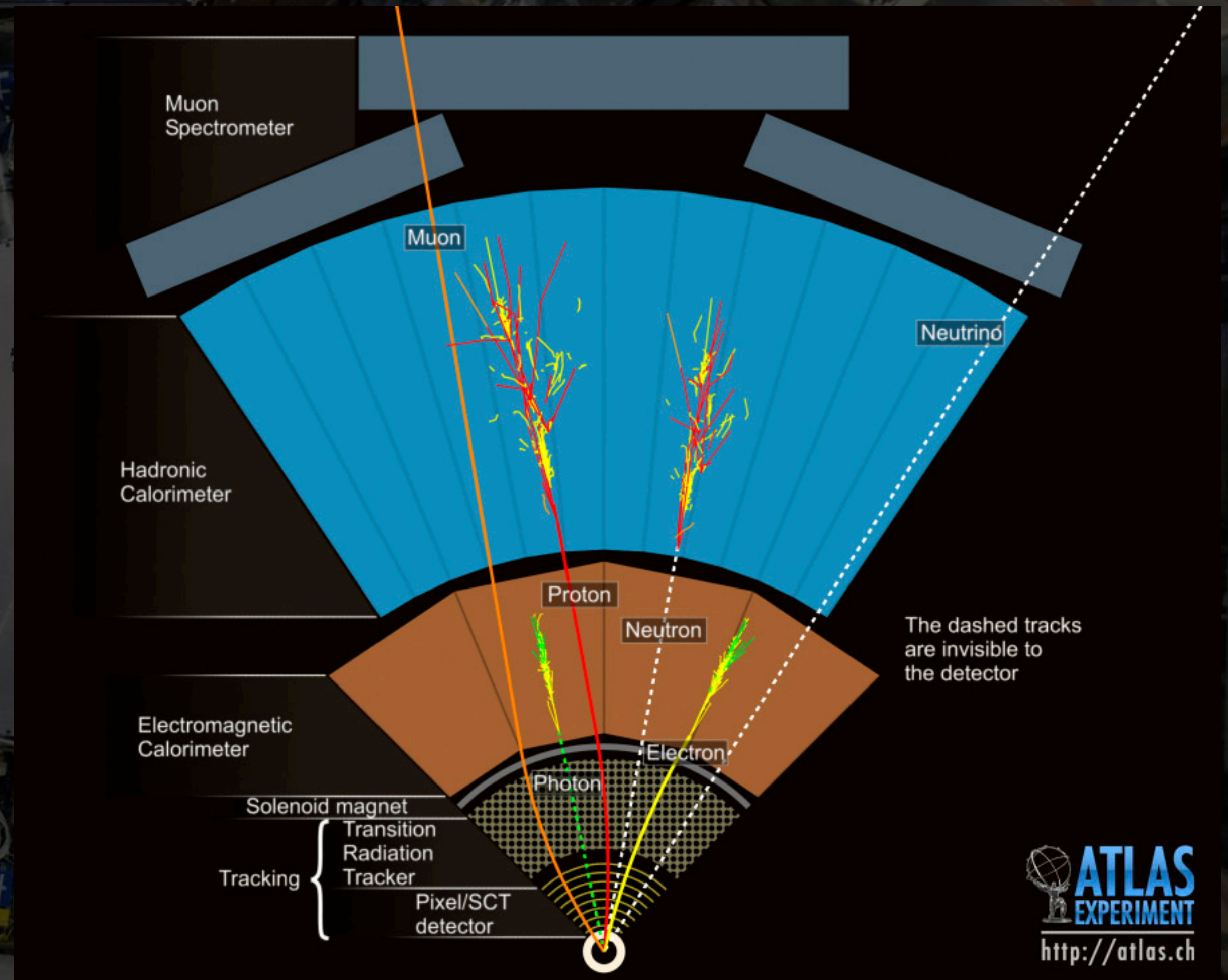

EVENT DISPLAY EXAMPLES

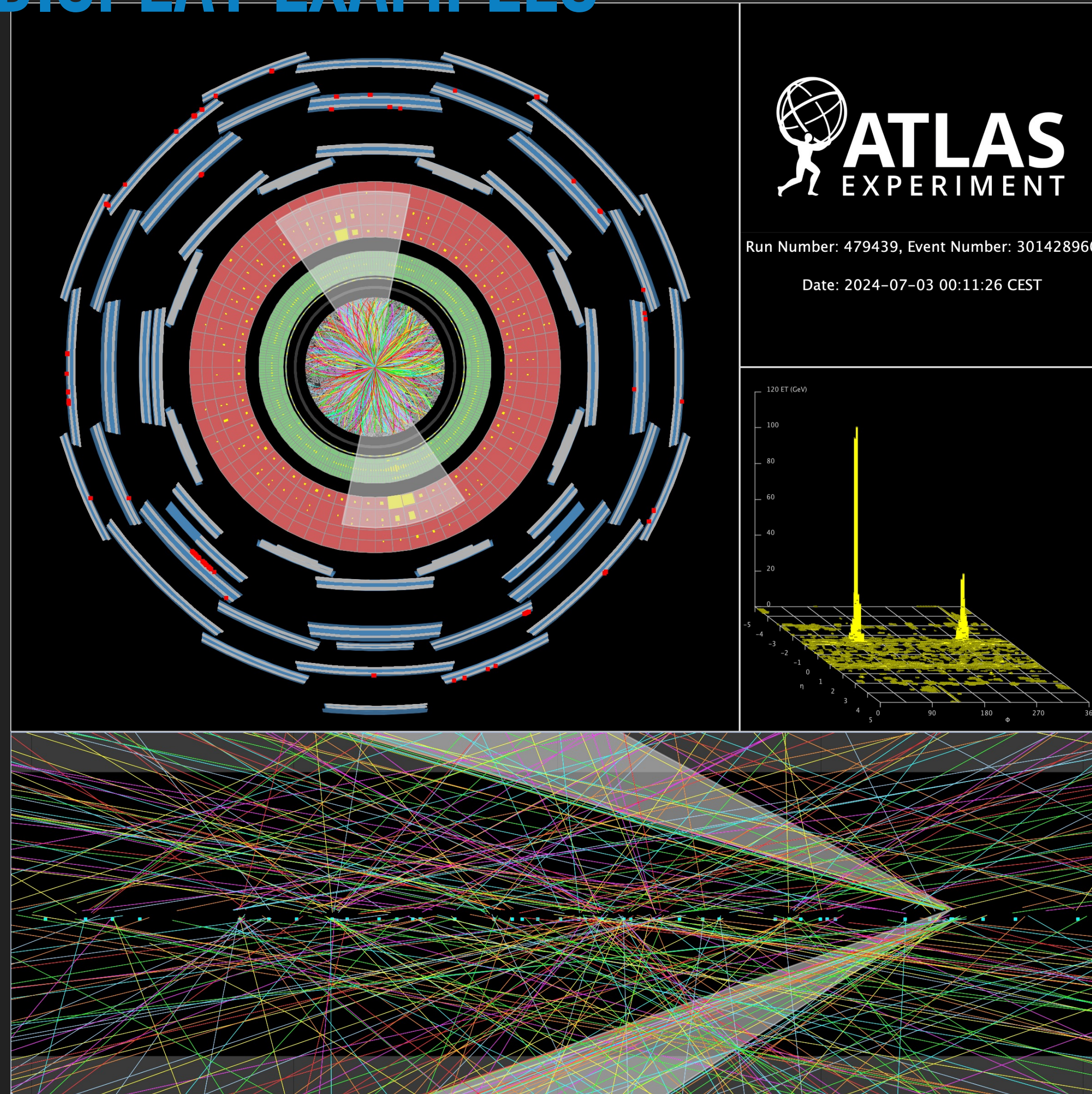

EVENT DISPLAY EXAMPLES

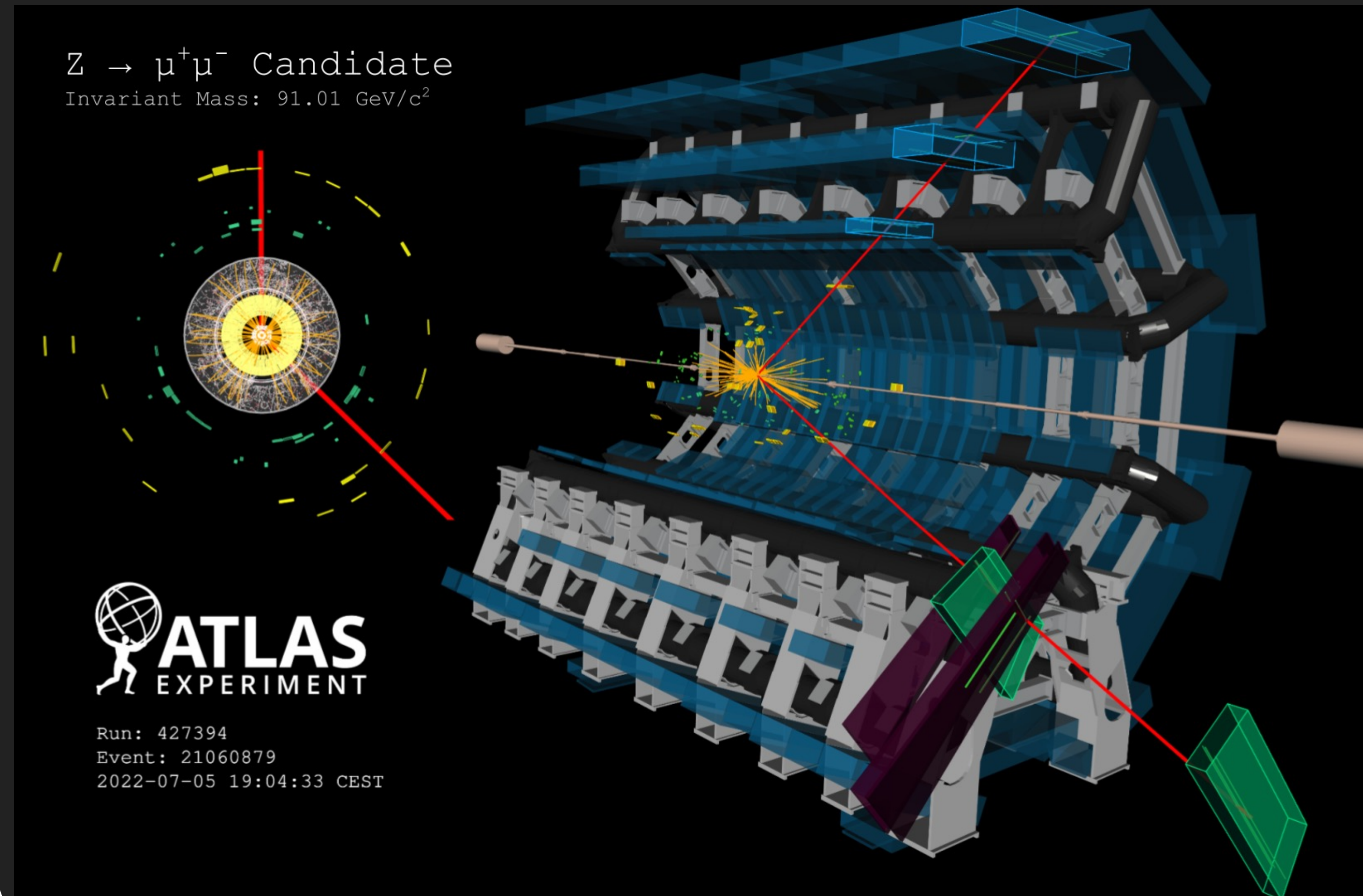

EVENT DISPLAY EXAMPLES

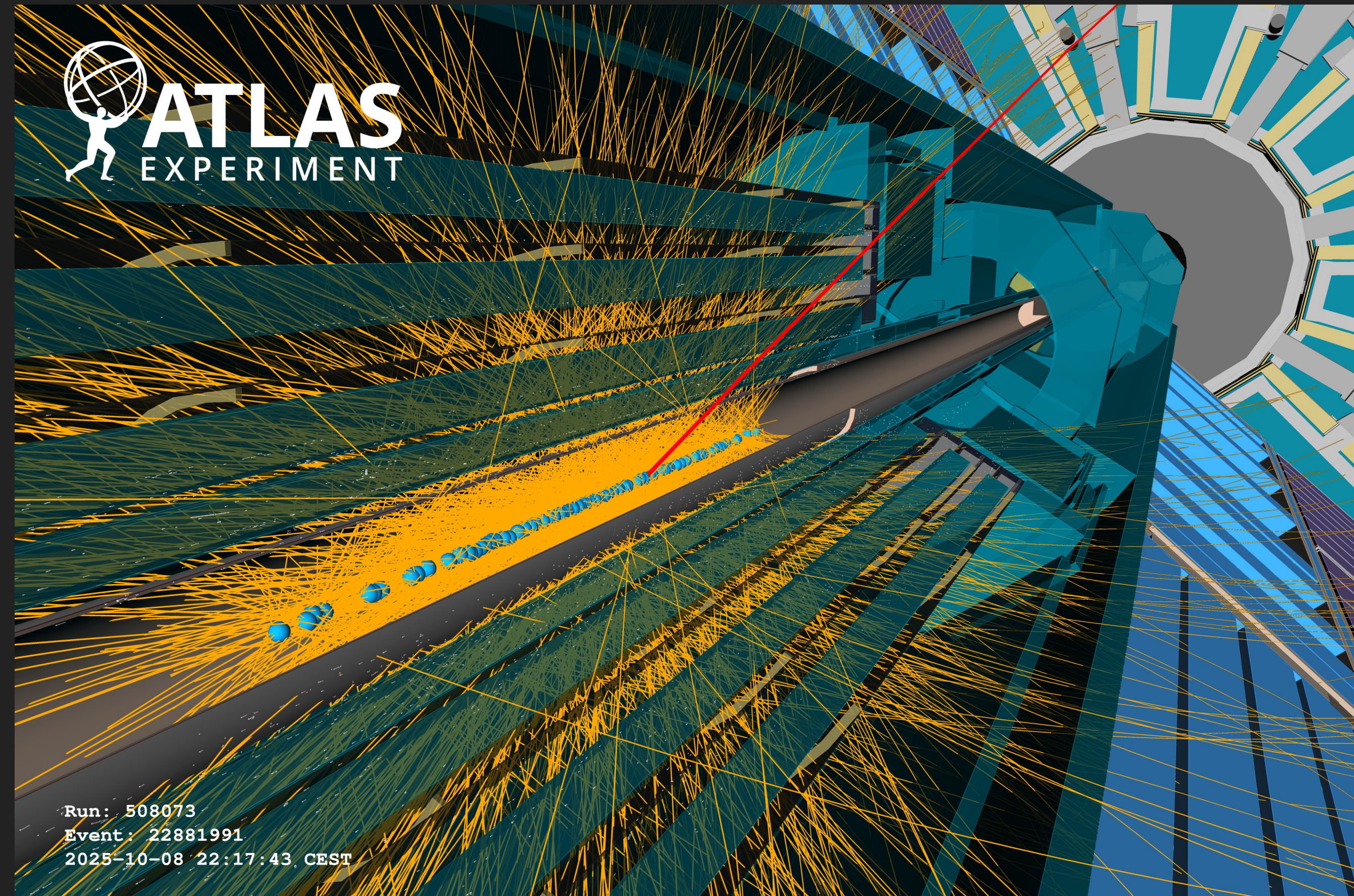

ATLAS & AFP

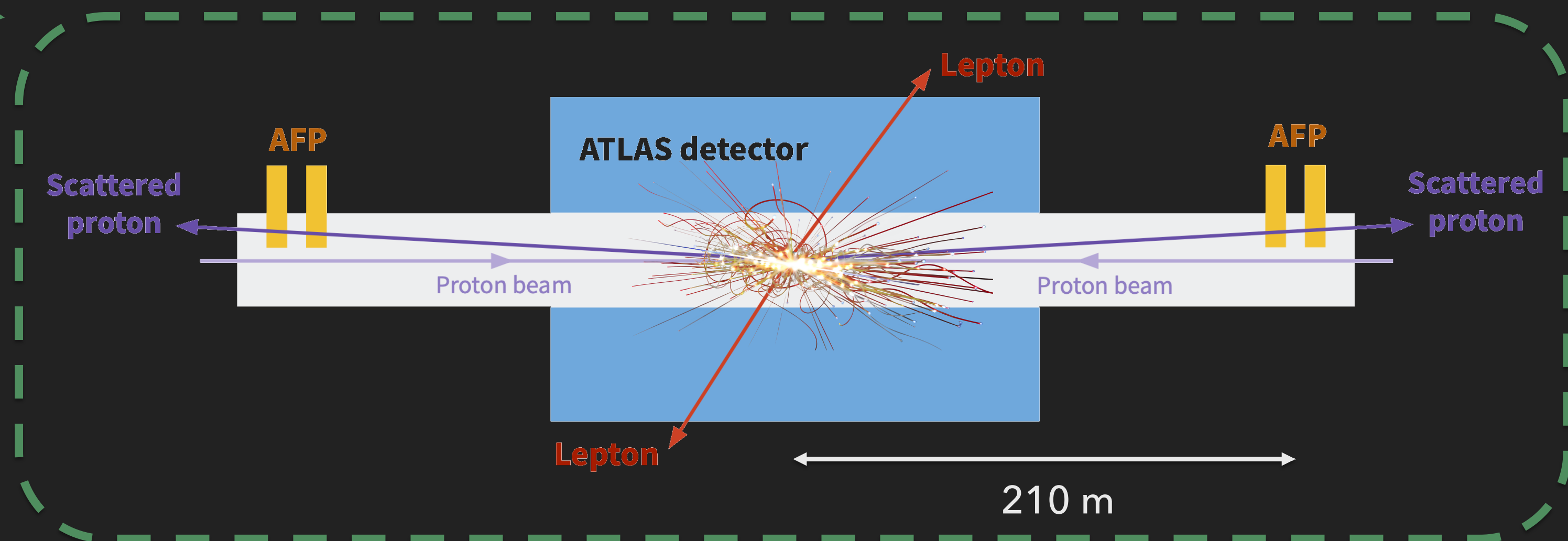
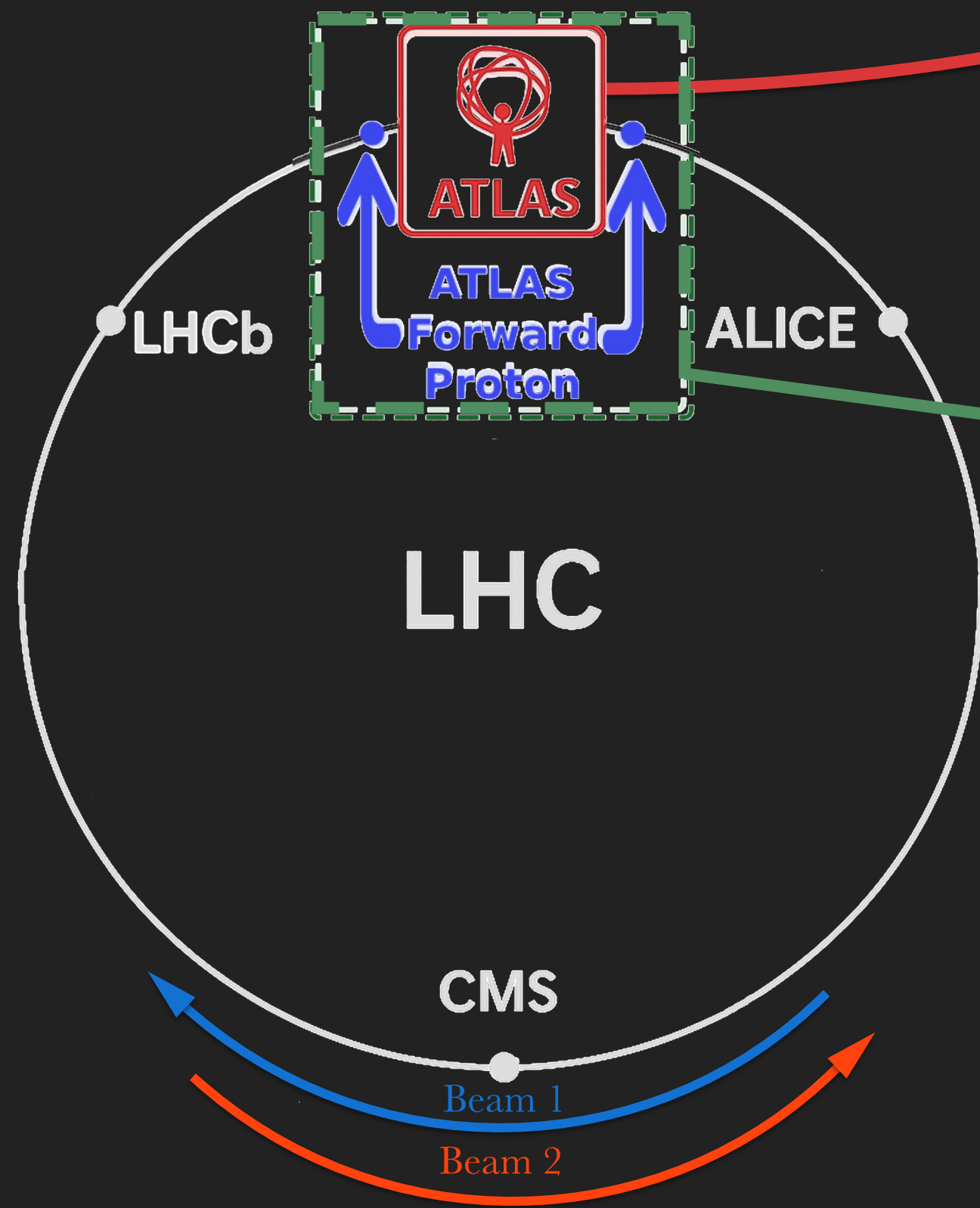
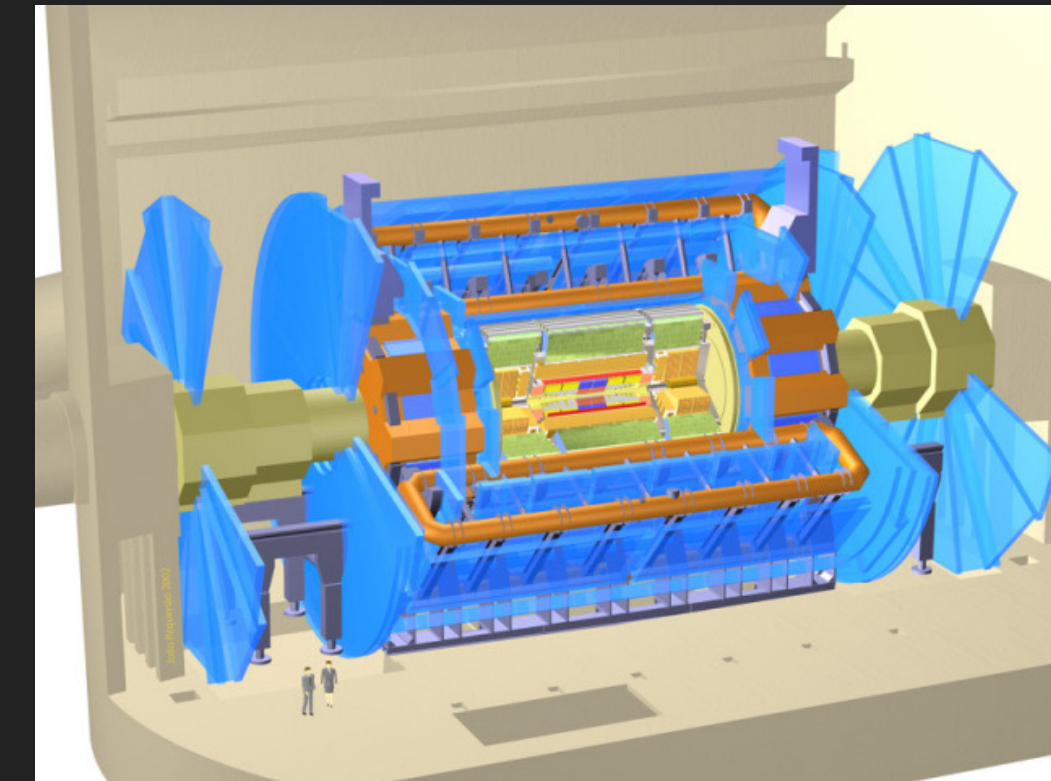

WHAT IS FORWARD PHYSICS ?

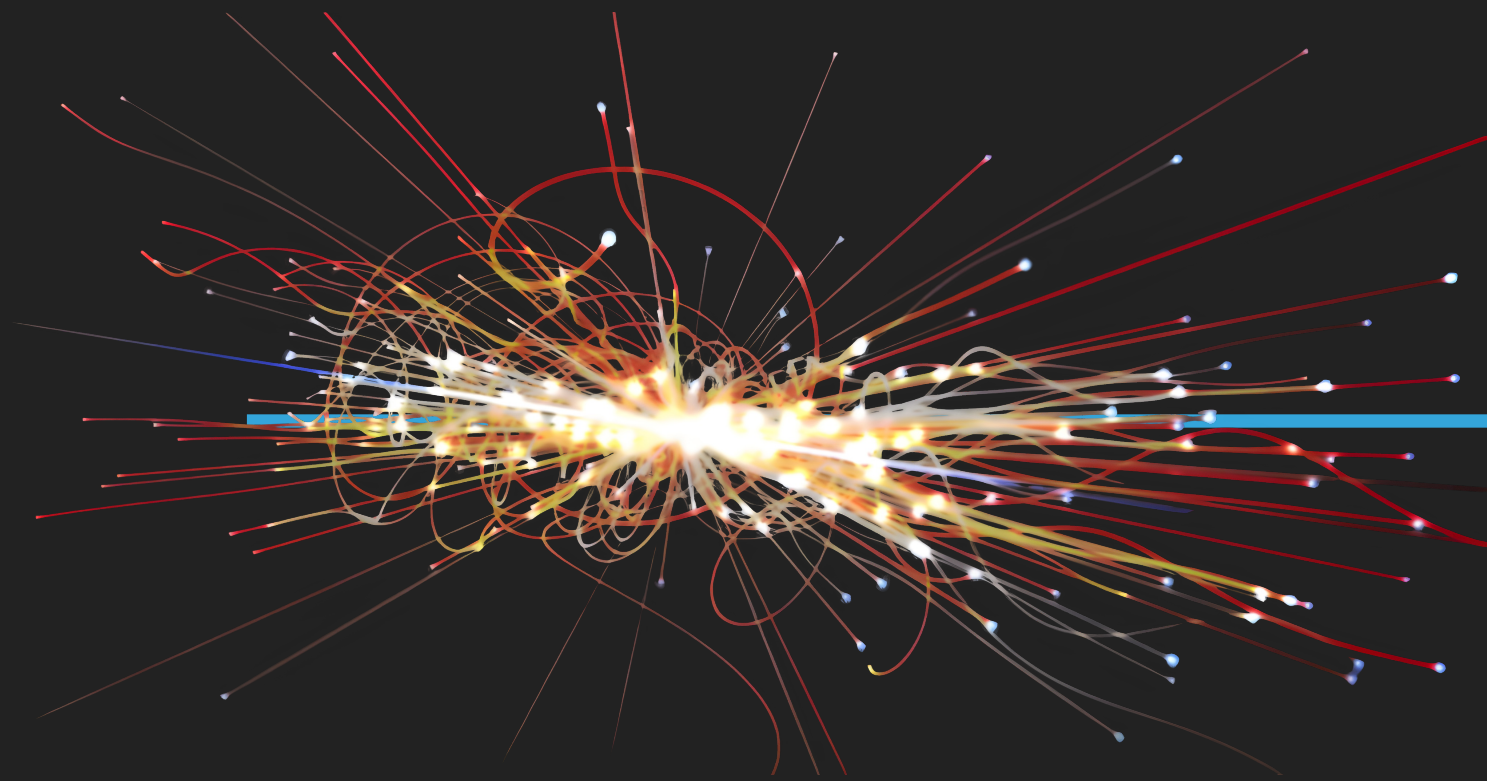

WHAT IS FORWARD PHYSICS ?

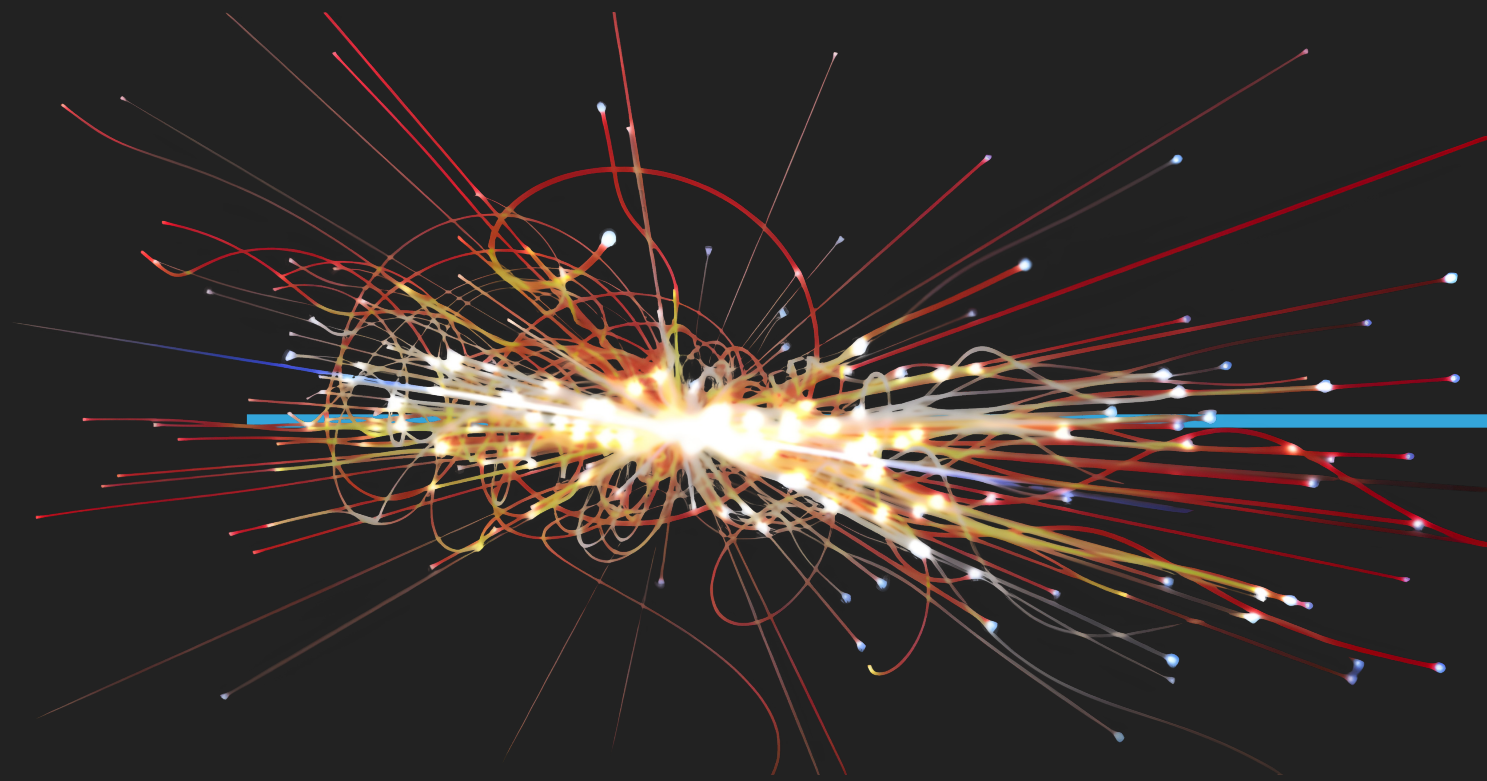

PROTON BEAM

PROTON SCATTERED AT A VERY SMALL ANGLE FROM THE BEAM

- DIFFRACTIVE
- PHOTON INDUCED

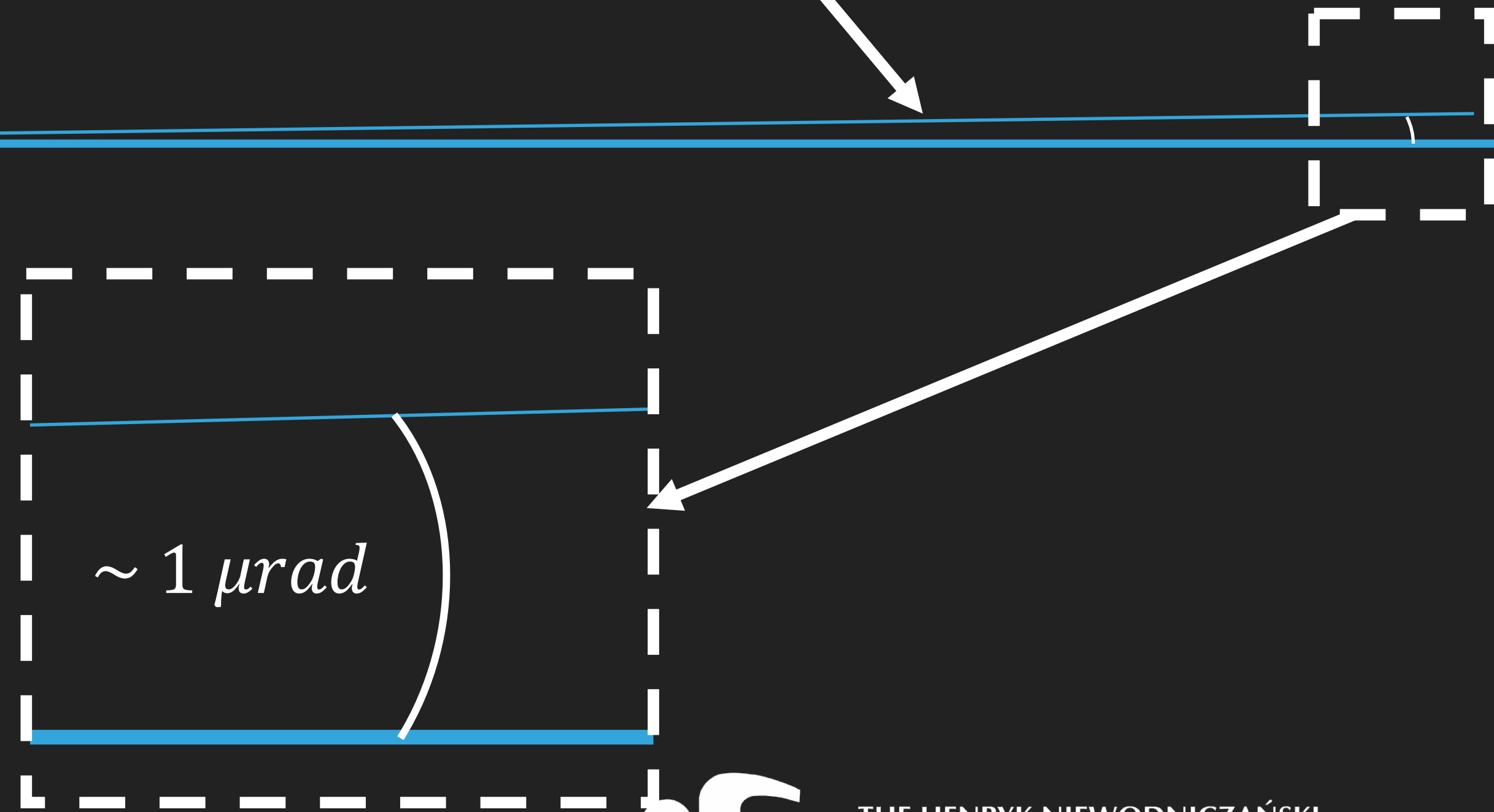

MOVED IN AND OUT OF THE BEAM PIPE

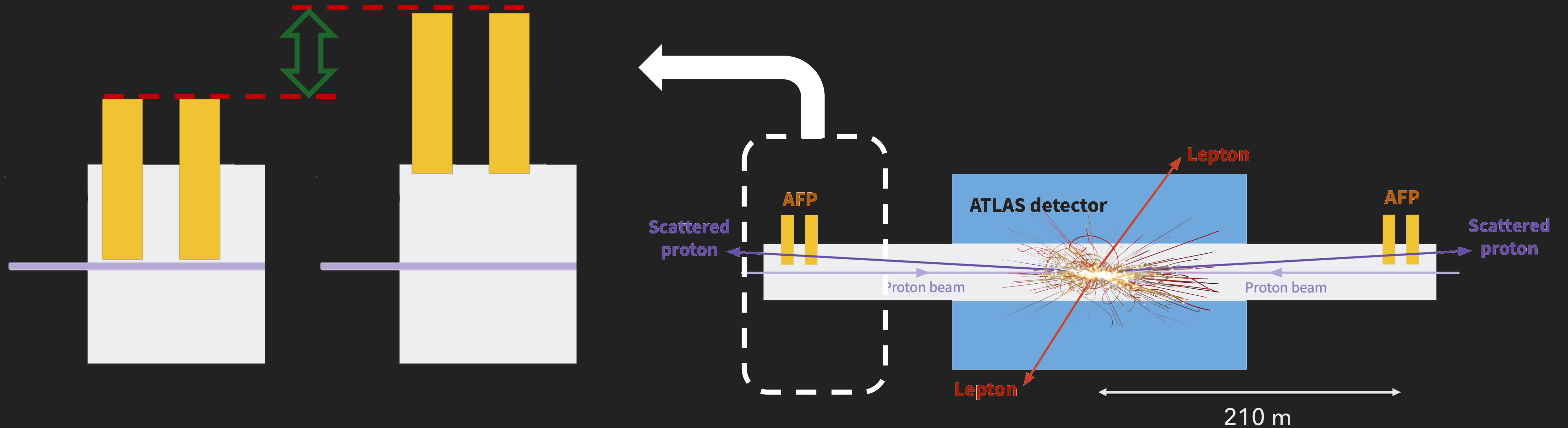

IN

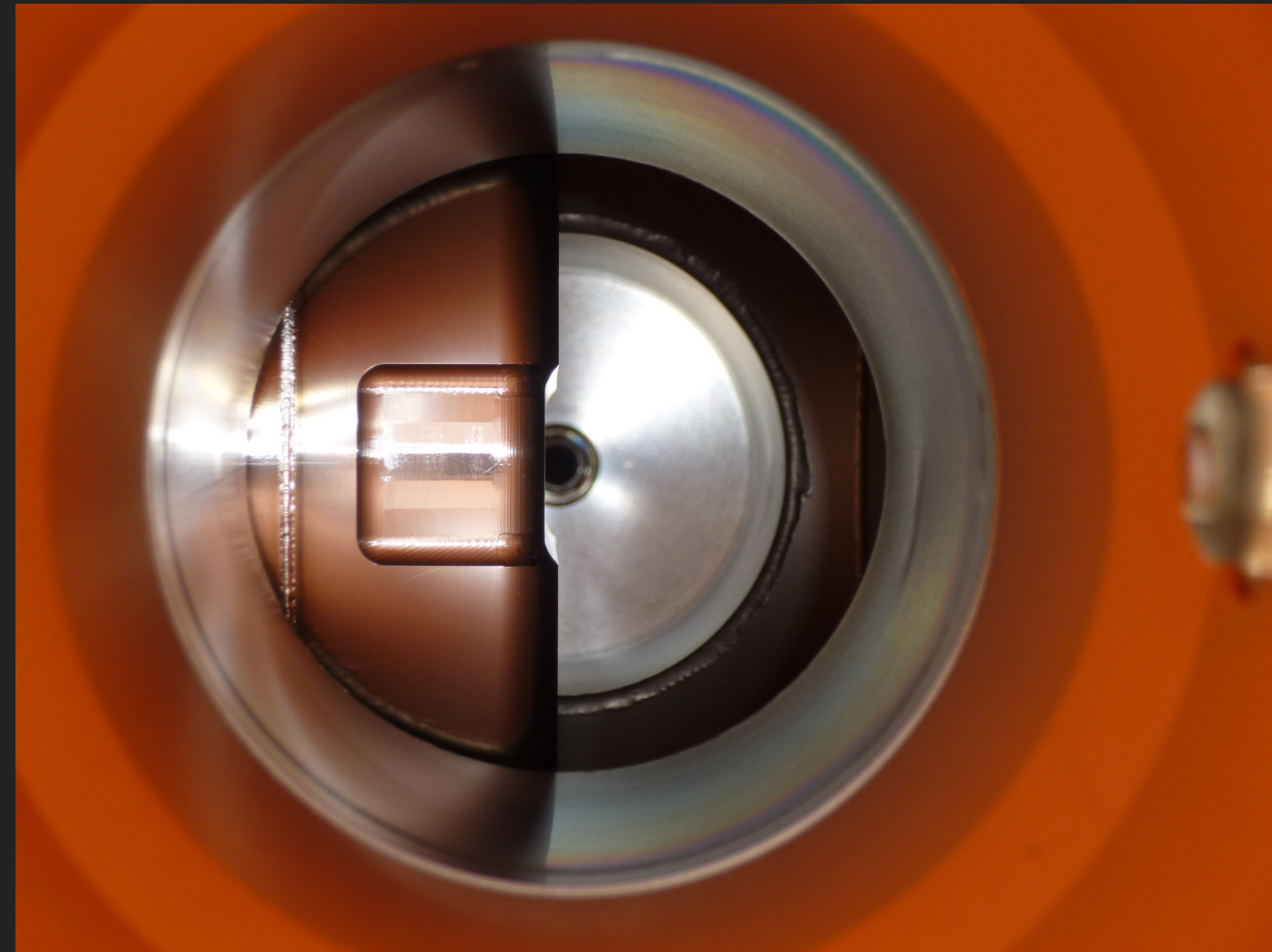

OUT

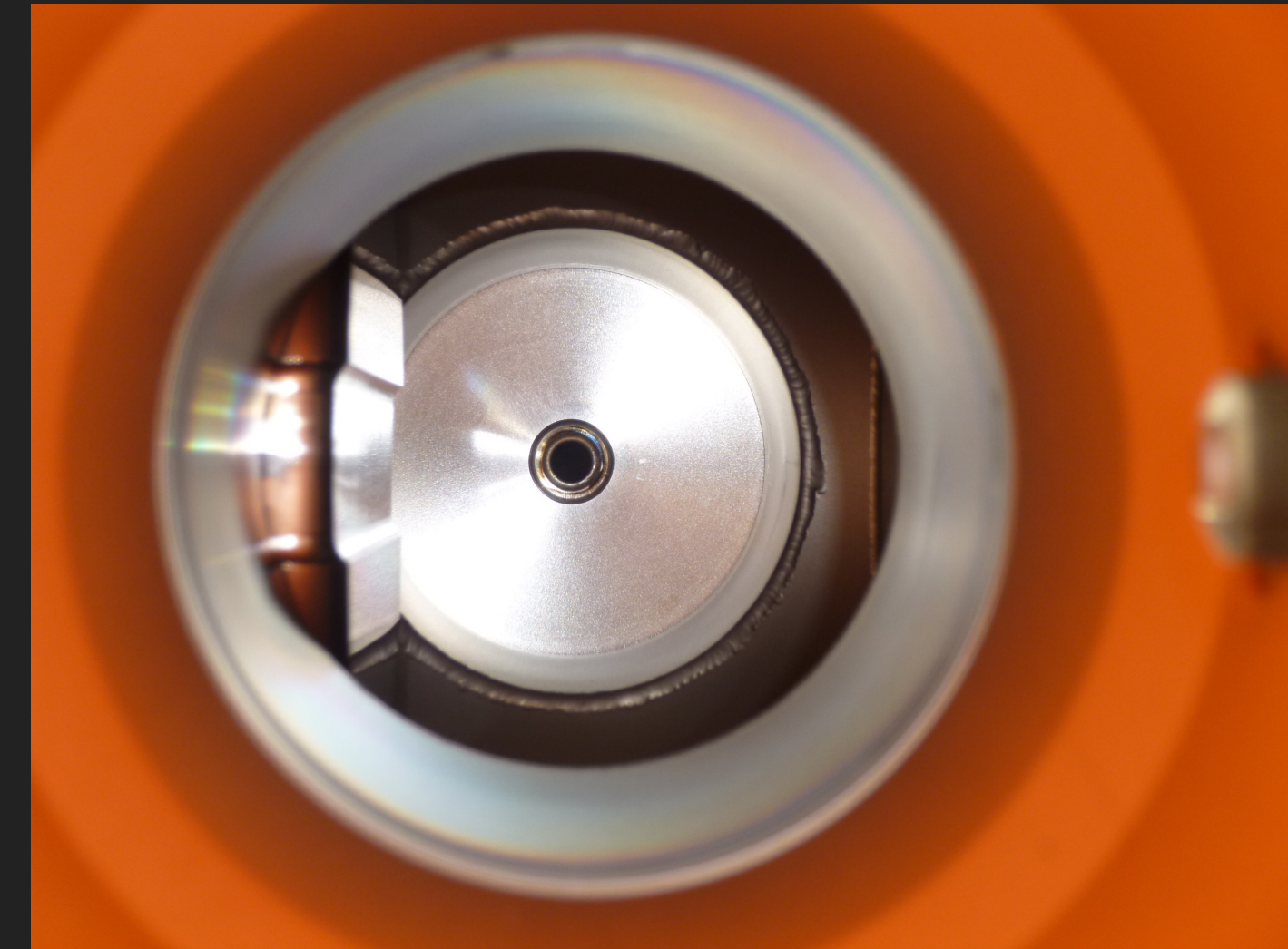

INSIDE THE ROMAN POT



RELATIVISTIC PROTONS AND ELECTROMAGNETIC FIELD AROUND THEM

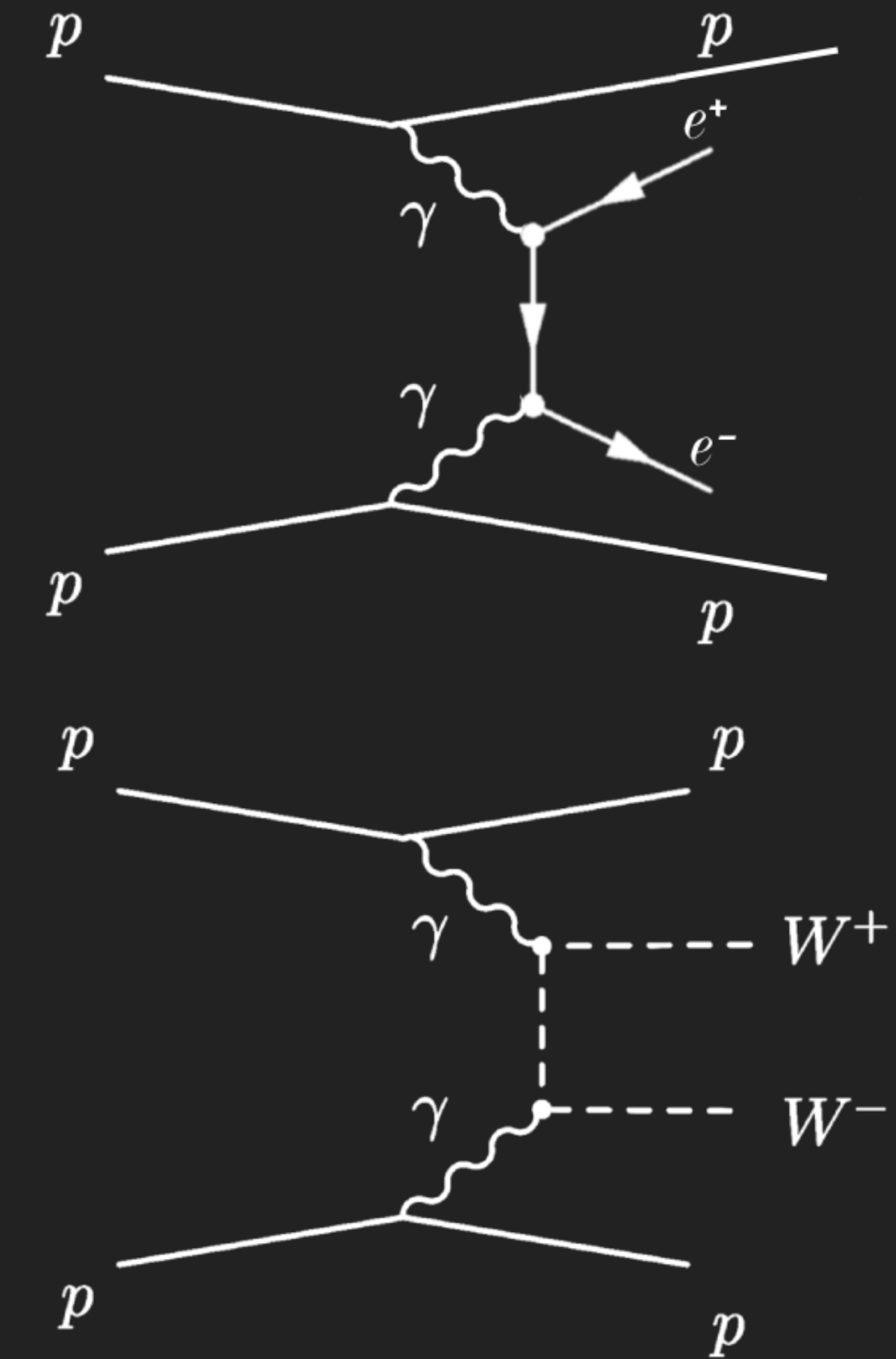
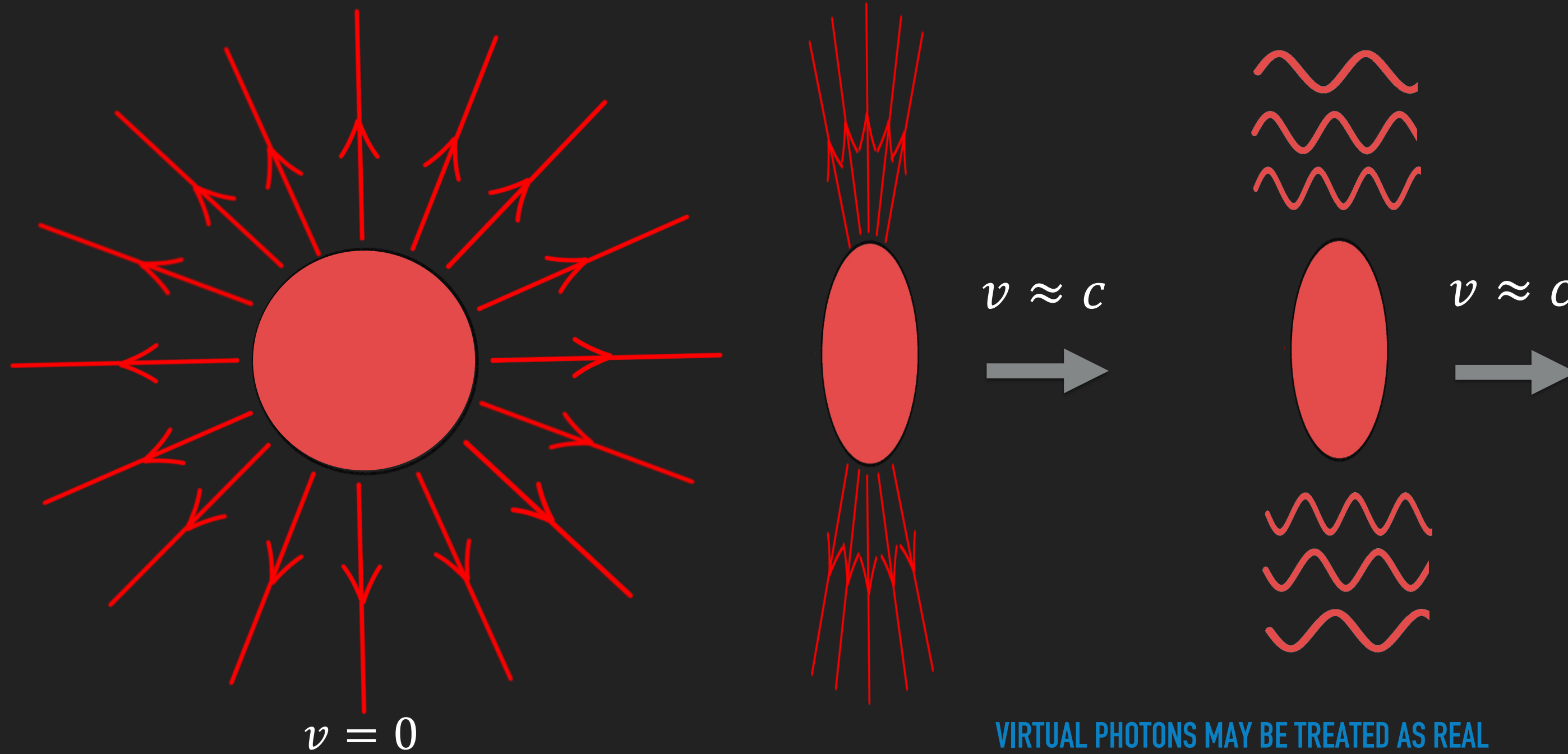

- ▶ Photon virtuality is small
- ▶ Proton remains intact or weakly excited
- ▶ Proton is ultra-relativistic
- ▶ Photon transverse momentum is small
- ▶ Process is dominated by QED interactions

FRACTIONAL ENERGY LOSS ξ

$$\xi = 1 - \frac{E_{proton}}{E_{beam}}$$

$$\xi_{ll}^{\pm} = \frac{m_{ll}}{\sqrt{s}} e^{\pm y_{ll}}$$

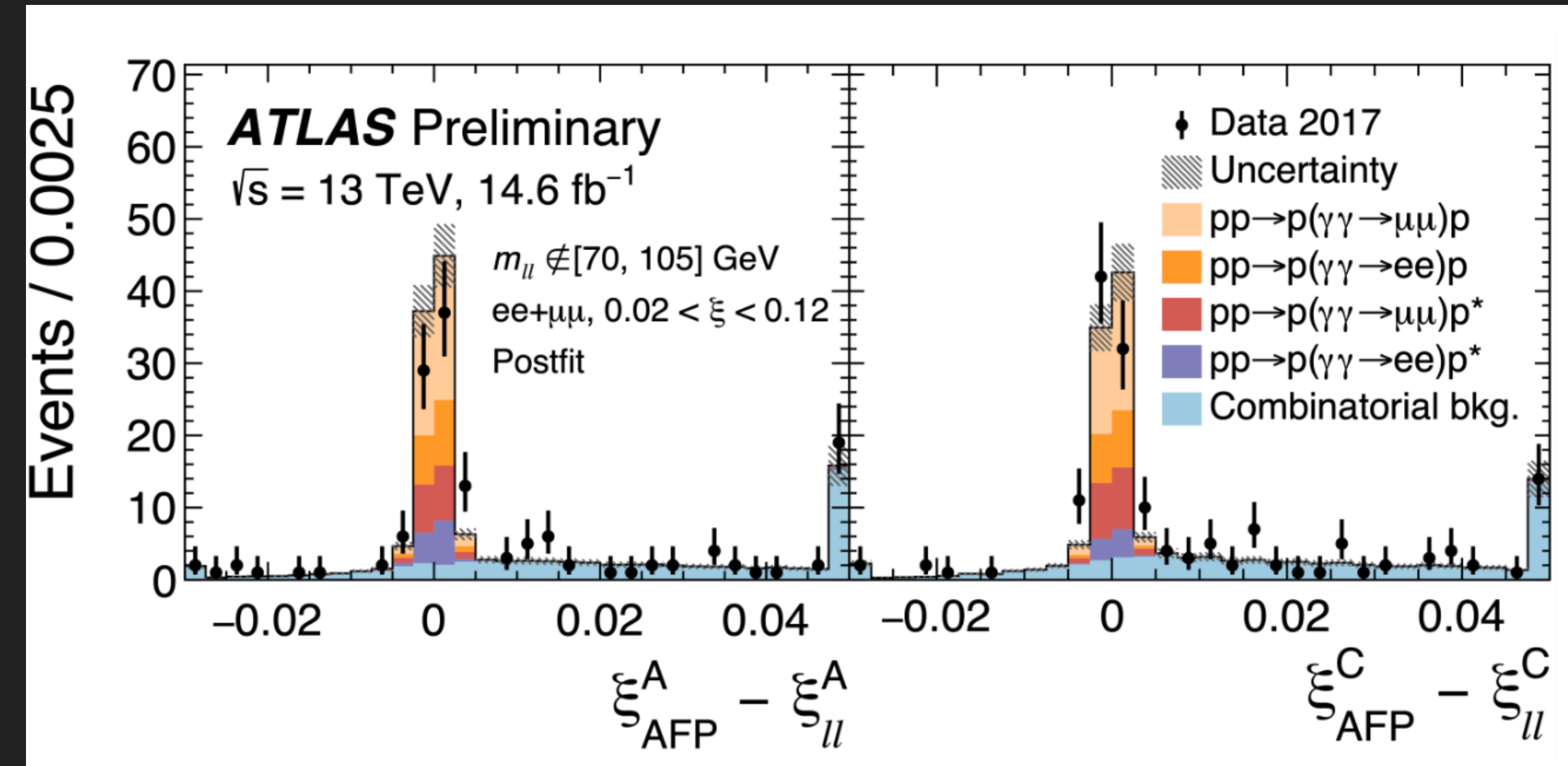

AFP MEASUREMENT PRINCIPLE

B field from LHC dipoles

1) Measure *spatial coordinate*

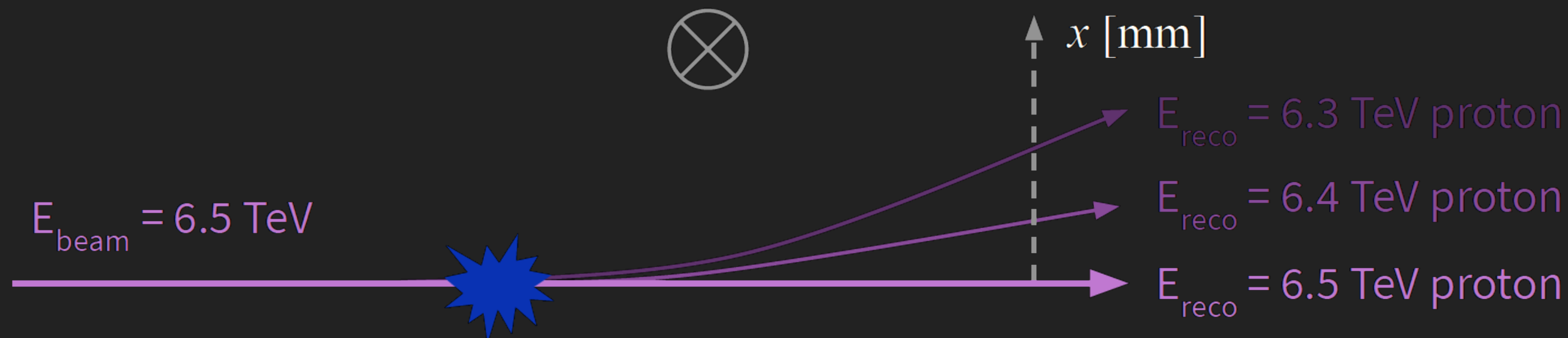

$$\xi_{\text{AFP}}^{\text{A,C}} = 1 - E_{\text{reconstructed}} / E_{\text{beam}}$$

2) Infer *energy lost by proton*

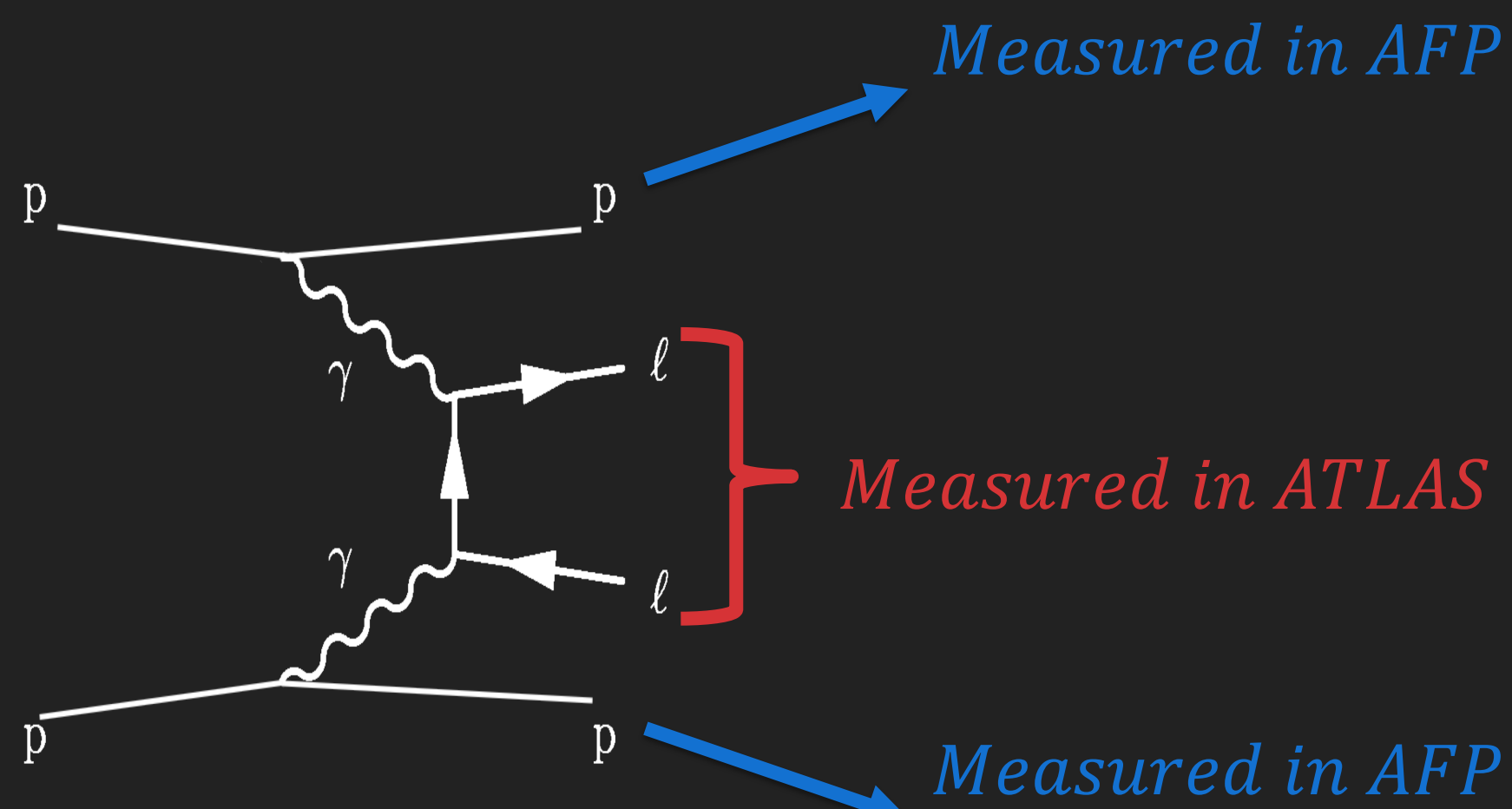

3) Know *initial photon energy*

$$\xi_{ll}^{\pm} = \frac{m_{ll}}{\sqrt{s}} e^{\pm y_{ll}}$$



MY ANALYSIS

▶ GOALS

- ▶ Observation and measurement of proton-tagged di-lepton production

- ▶ $pp \rightarrow p(\gamma\gamma \rightarrow ee)p^{(*)}$

- ▶ $pp \rightarrow p(\gamma\gamma \rightarrow \mu\mu)p^{(*)}$

▶ MOTIVATION

- ▶ Proton dissociation
- ▶ Soft survival effect factor
- ▶ QED testing (Schwinger limit exceeded - electromagnetic fields surrounding protons are sufficiently intense to allow spontaneous lepton pair creation)
- ▶ Photon collision physics: higgs production, supersymmetry, dark matter searches, axion-like particles etc.

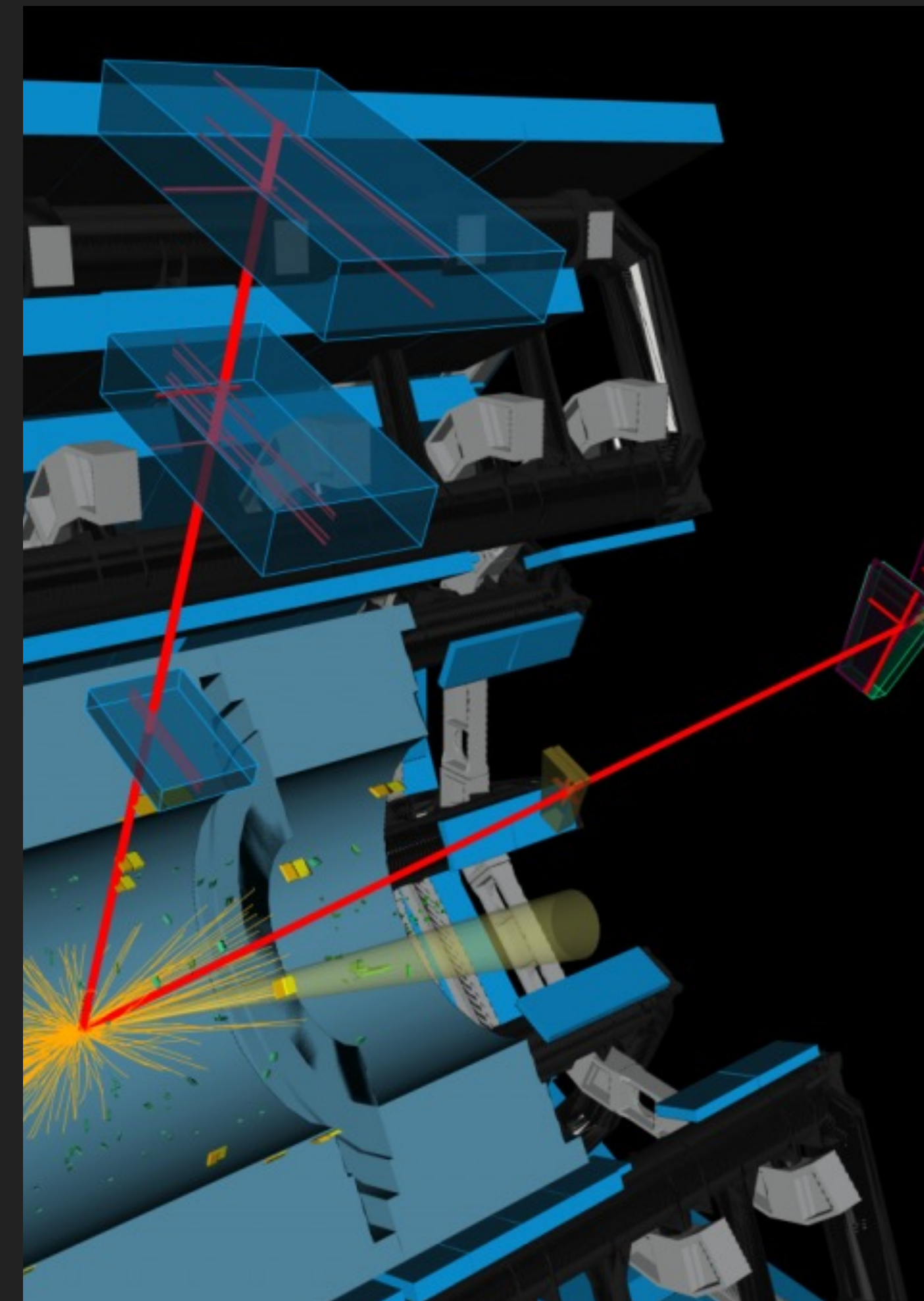

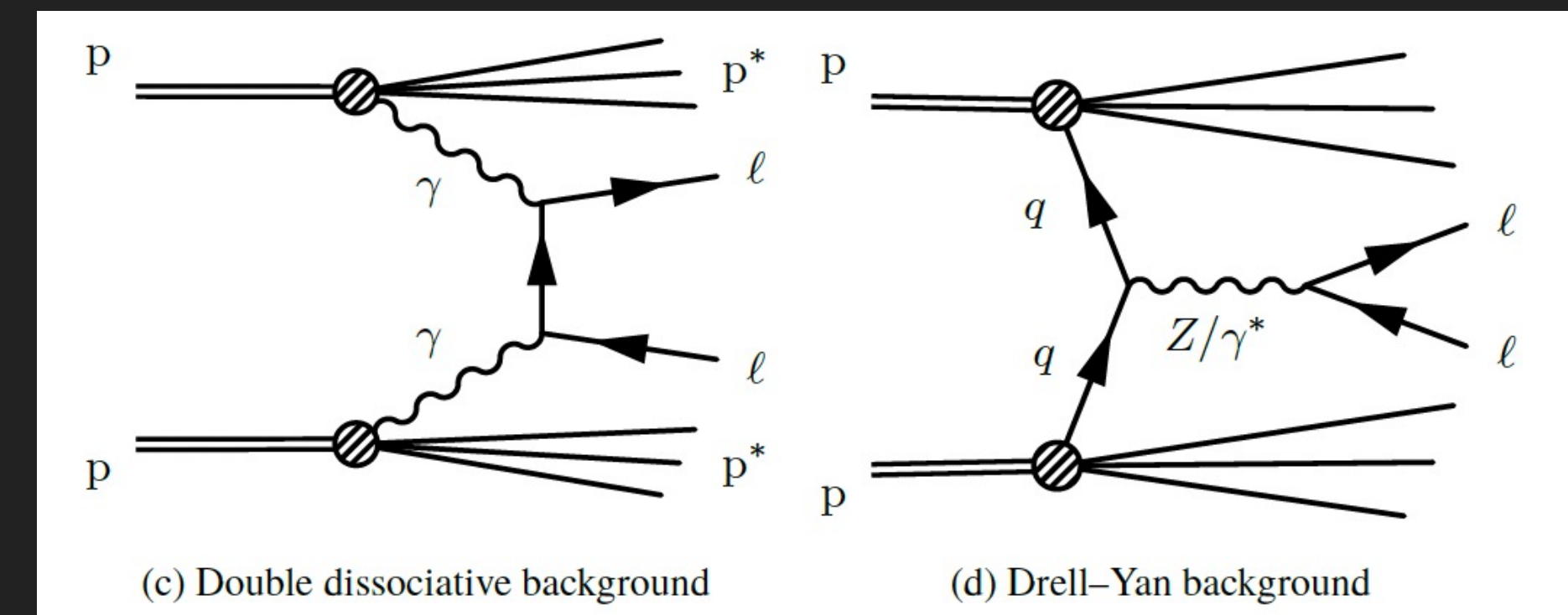
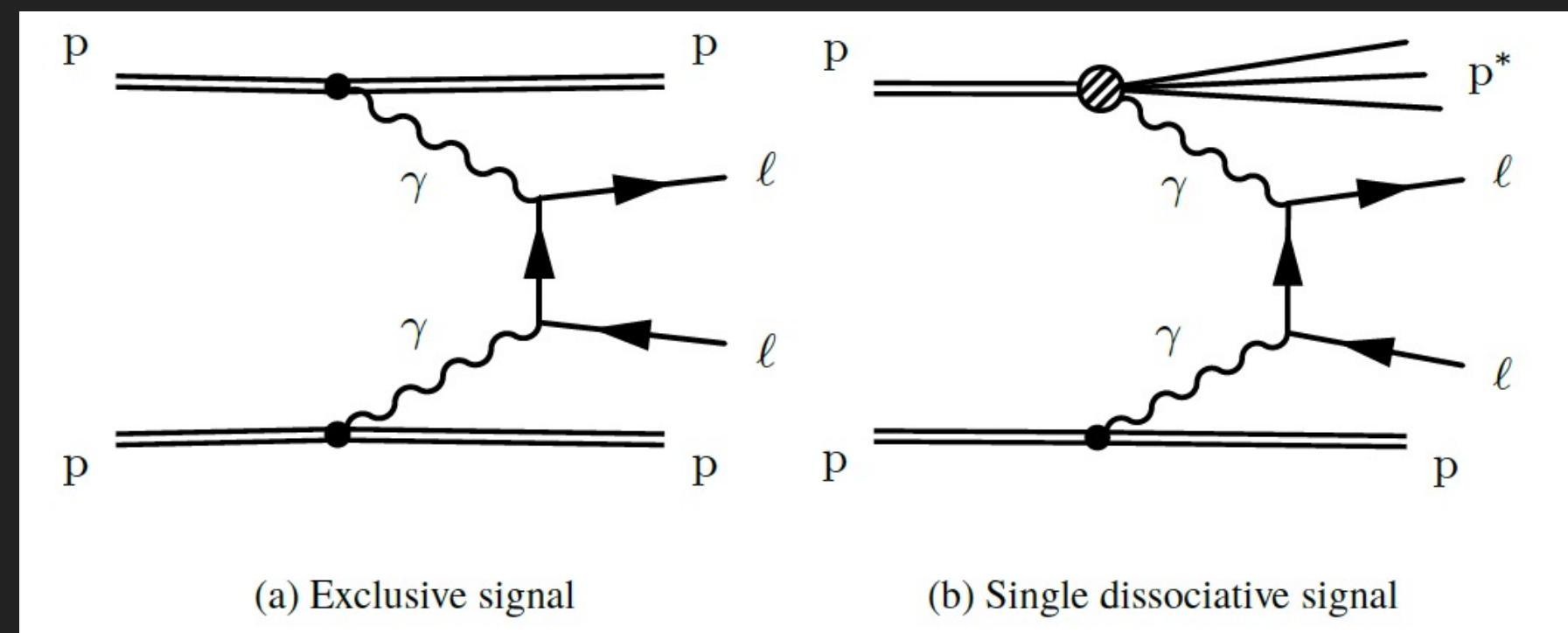
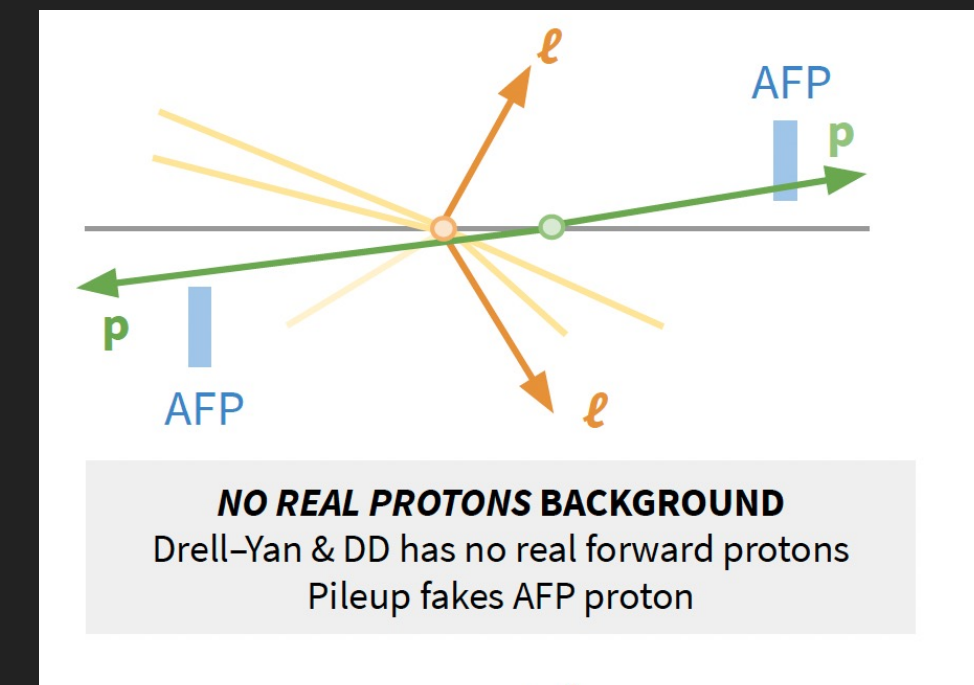
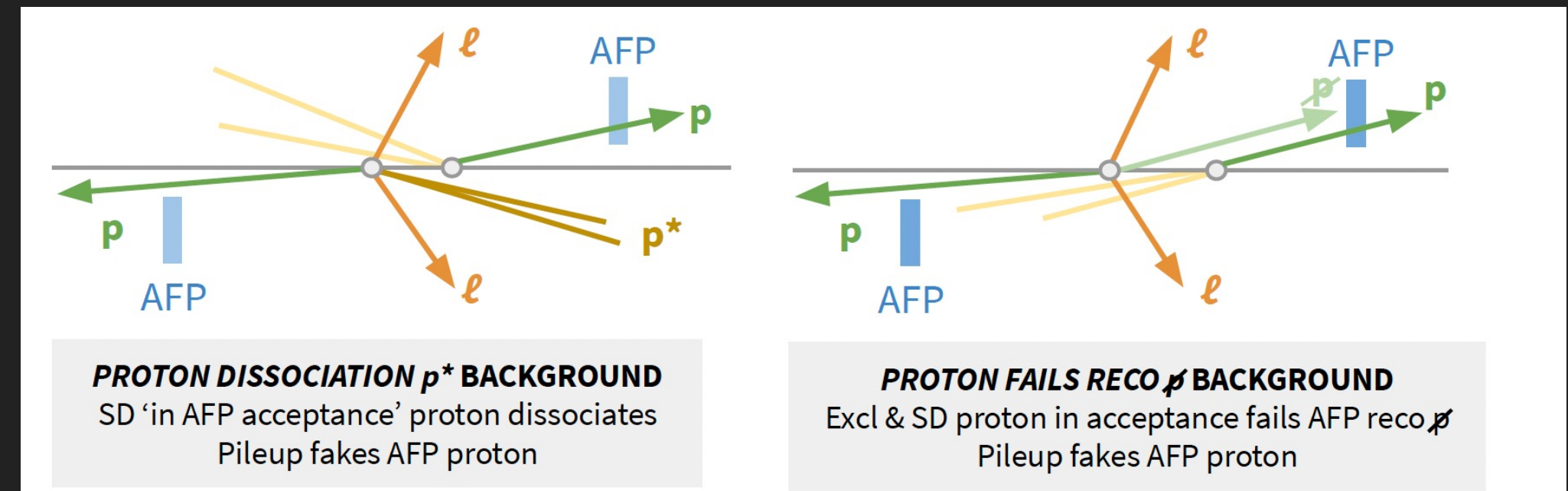
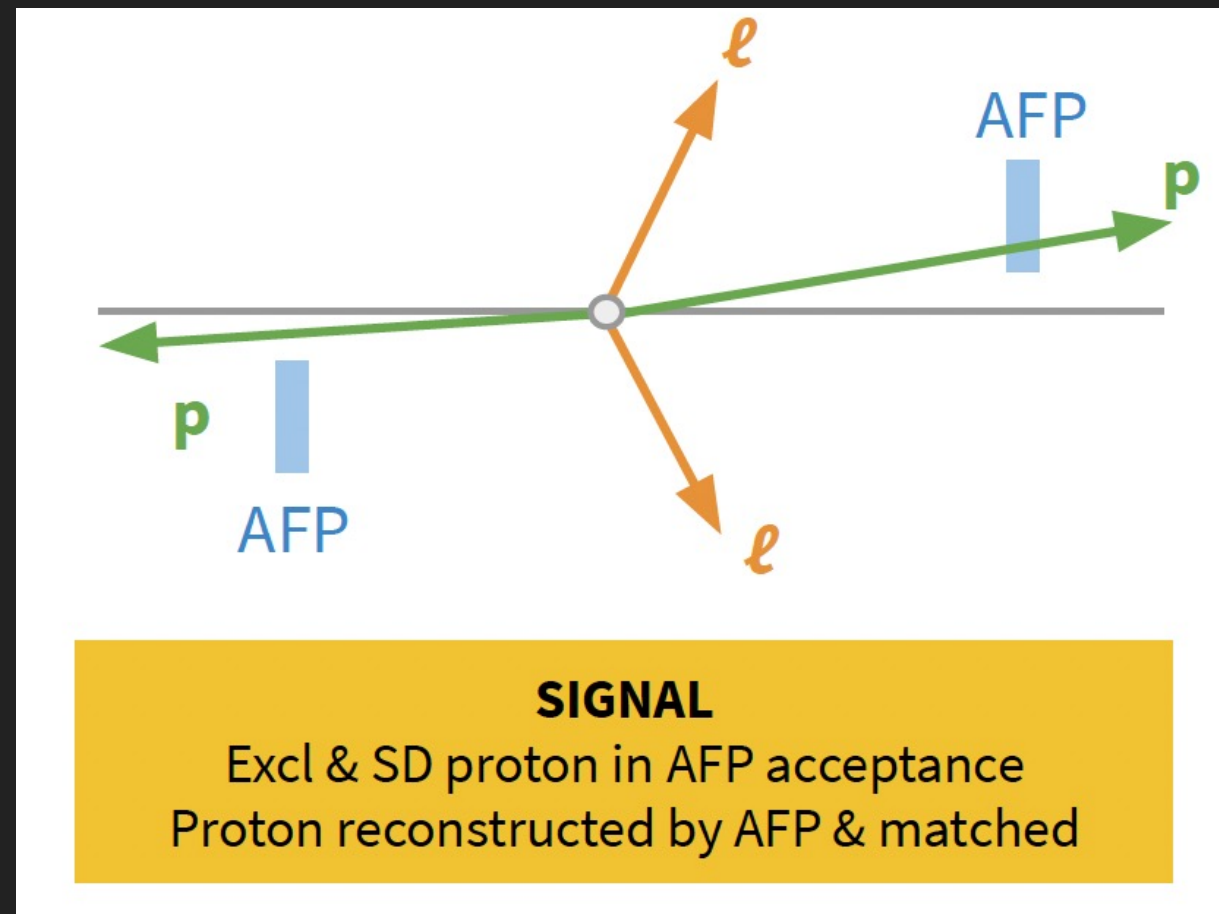

EXCLUSIVITY REQUIREMENTS

Tracks nearby vertex veto

$$N_{tracks}^{0.5\text{ mm}} = 0$$

- ▶ only two leptons produced
- ▶ no color exchange between protons
- ▶ no additional charged particles

Low acoplanarity/dilepton pT

$$A_{\phi}^{ll} = 1 - \frac{|\Delta\phi_{ll}|}{\pi} < 0.01$$

$$\vec{p}_T(l^+) + \vec{p}_T(l^-) \cong 0$$

- ▶ Clean, exclusive EM production
- ▶ No QCD interactions
- ▶ Incident photons have very small pT

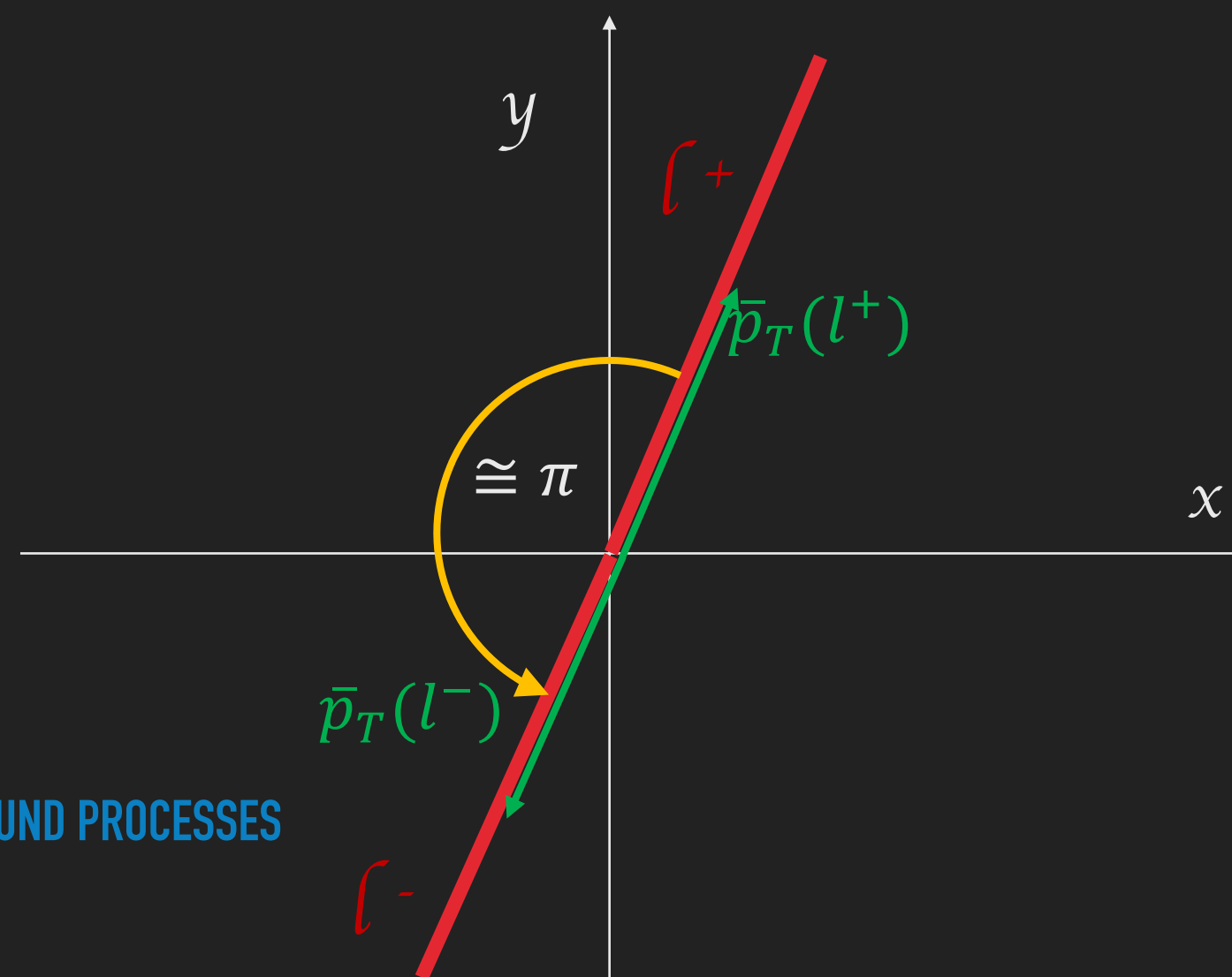
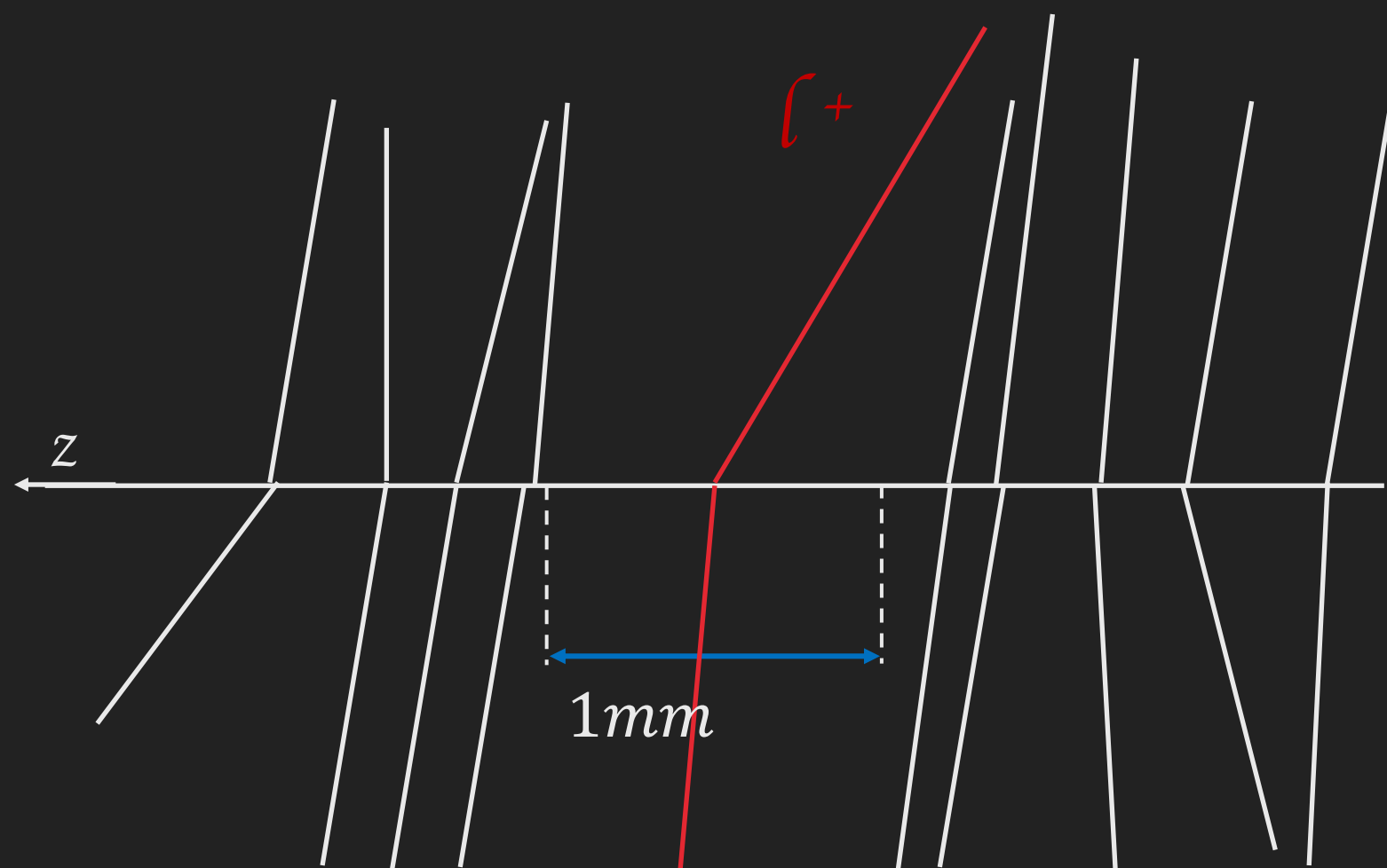

SEPARATES FROM BACKGROUND PROCESSES

- ▶ Drell-Yan
- ▶ Z/gamma -> ll
- ▶ W + jets
- ▶ Multi-jet fakes

- ▶ Kinematic matching of forward protons with the central dilepton system $\Delta\xi \cong 0$

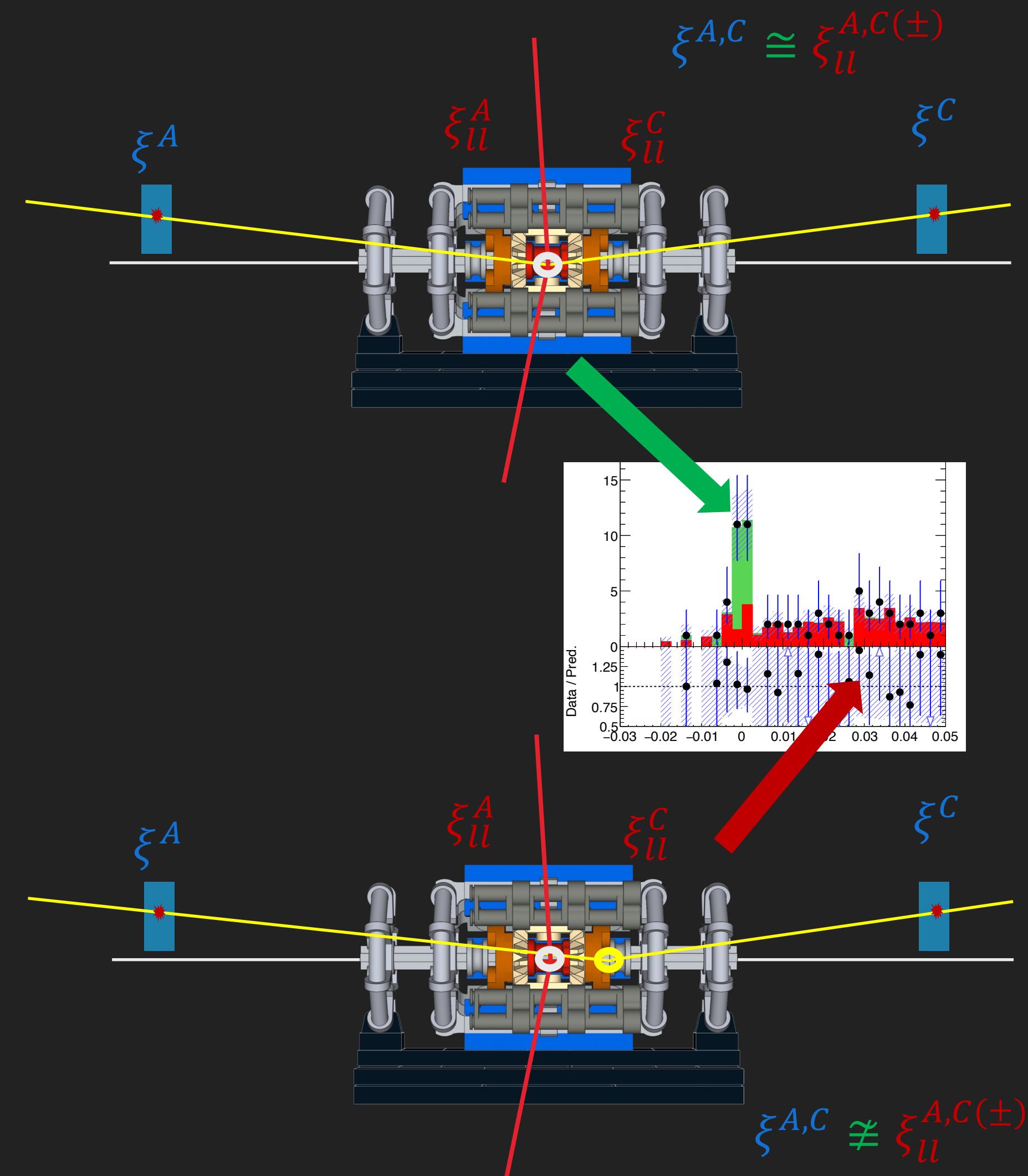

INITIAL RESULTS

$$\xi^{A,C} = 1 - \frac{E_{proton}^{A,C}}{E_{beam}}$$

$$\xi_{ll}^{A,C(\pm)} = \frac{m_{ll}}{\sqrt{s}} e^{\pm y_{ll}}$$

$$\Delta \xi^{A,C} = \xi^{A,C} - \xi_{ll}^{A,C(\pm)}$$

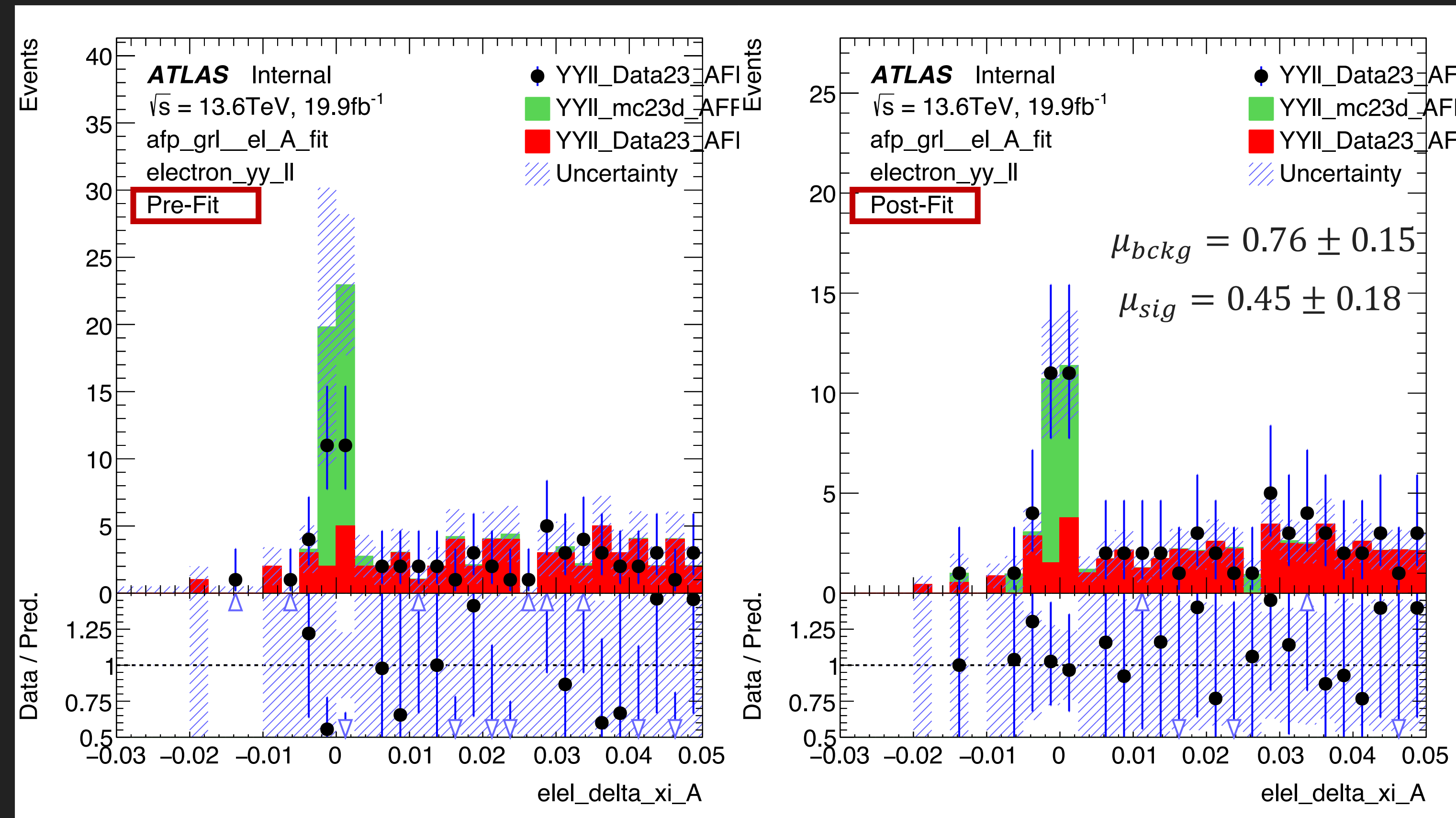

FITTING TO THE DATA

- ▶ Signal Monte Carlo (Madgraph, Pythia8 for $\gamma\gamma \rightarrow ll$)
- ▶ Combinatorial background (mixed events)
- ▶ 2023 data



THE HENRYK NIEWODNICZAŃSKI
 INSTITUTE OF NUCLEAR PHYSICS
 POLISH ACADEMY OF SCIENCES

INITIAL RESULTS

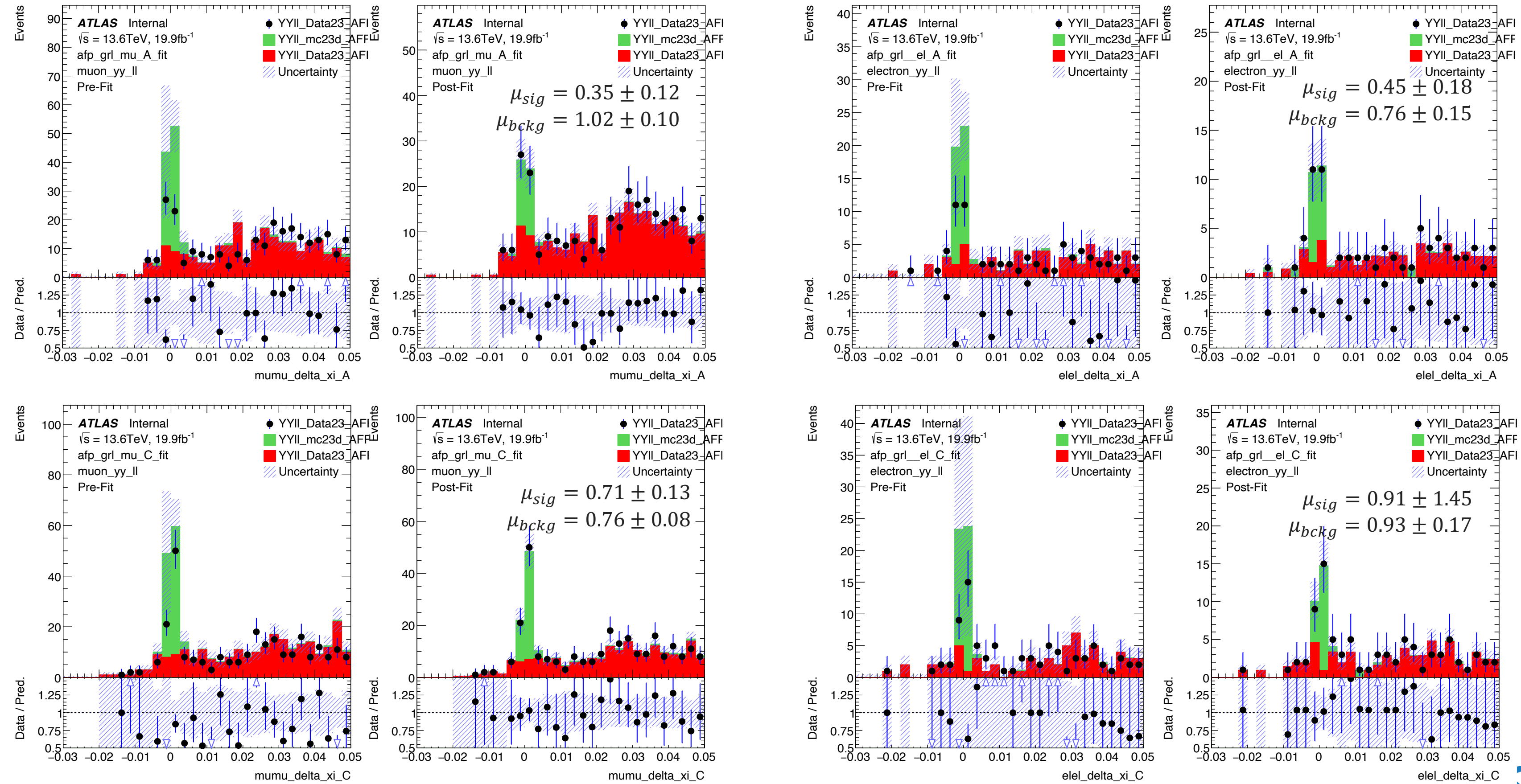

THANKS FOR ATTENTION

Q&A